

“**Products, service, know-how**”



Robert-Bosch-Straße 35  
42489 Wülfrath  
T 02058 - 78 28 00 - 0

F 02058 - 78 28 00 - 49  
info@wagnergmbh.de  
www.wagnergmbh.de

# Contents

<b>A Series</b>	Brushless Motors	8 - 19
<b>B Series</b>	Synchronous Motors	20 - 25
<b>C Series</b>	Stepper Motors	26 - 35
<b>D Series</b>	Brush Torque Motors	36 - 55
<b>E Series</b>	ATEX Brushless Motors	56 - 63
<b>Custom</b>	Custom Motors	64 - 71

F 02058 - 78 28 00 - 49  
 info@wagnergmbh.de  
 www.wagnergmbh.de

Robert-Bosch-Straße 35  
 42489 Wülfrath  
 T 02058 - 78 28 00 - 0



## Expertise at your service

All-around services and solutions. A product selection and software development are the best proposal for specific applications. In the automation and motion control industry since 1980, Servotecnica manufactures and proposes unique products based on cutting-edge technologies developed by leading global manufacturers.

The concernment of giving a wide range of products guarantees its presence in all sectors of the industry requiring high performances, skilled engineers, reducing machine developing time and offering a service support which grants a reliable partner for your applications.

F 02058 - 78 28 00 - 49  
info@wagnergmbh.de  
www.wagnergmbh.de

Robert-Bosch-Straße 35  
42489 Wülfrath  
T 02058 - 78 28 00 - 0

**WAGNER GMBH**  
Elektrotechnische Systemlösungen



## Custom

Thanks to our very lean, flexible production, we can deliver samples specifically designed according to the explicit requirements of an application in a very short time, thus being always able to identify the best solution for each application.



## The widest range of Technologies

Having a wide range of technologies available - brush, brushless, stepper and synchronous motors - we are always able to provide the suitable motorised system thanks to extensive know-how that gets our motor lines to the top of reference markets and makes it possible for us to be a sole supplier for different types of applications.



**WAGNER GMBH**  
Elektrotechnische Systemlösungen

Robert-Bosch-Straße 35  
42489 Wülfrath  
T. 02058 - 78 28 00 - 0

F. 02058 - 78 28 00 - 49  
info@wagnergmbh.de  
www.wagnergmbh.de

C SERIES

B SERIES

A SERIES

CONTENTS

# Industries

## Electronics



Semiconductors  
Test  
Wafer

## Aerospace



Air  
Land  
Sea

## Medical

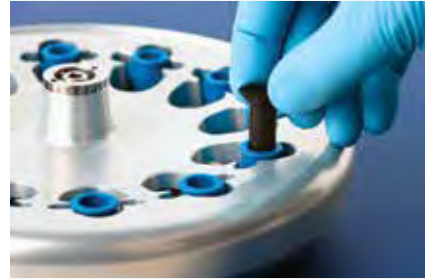

Diagnosis  
Pharm & Beauty  
Radiology  
Odontology  
Mobile tools

## Robotics



Humanoid robotics  
Inspection robotics  
Flexible automation  
Welder's tongs

## Packaging



Filling & labelling  
Capping  
Food & beverage  
Packaging  
Scales

## Automatic doors



Lifts  
Linear doors  
Revolving doors  
Locks

F 02058 - 78 28 00 - 49  
info@wagnergmbh.de  
www.wagnergmbh.de

Robert-Bosch-Straße 35  
42489 Wülfrath  
T 02058 - 78 28 00 - 0



## Machine tool



Machine centre  
Sheet metal forming  
Electrical discharge  
Press machines  
Lathe machines

## Energy



Renewable energy  
Not renewable energy  
Wind turbines

## Converting



Digital ink jet  
Flexographic printing  
Offset printing  
Plane printing  
Rotogravure

## Amusement parks



Merry-go-round

## Plastics



Blow molding  
Plastic bags  
Extrusion

## Oil & gas



Oil  
Gas  
Atex  
Valves

F 02058 - 78 28 00 - 49  
info@wagnergmbh.de  
www.wagnergmbh.de

Robert-Bosch-Straße 35  
42489 Wülfrath  
T 02058 - 78 28 00 - 0



# SVTM A Series

## Brushless Motors





# SVTM A Series

## Brushless Motors



CUSTOMISABLE



LOW VOLTAGE



STURDY

Our Brushless motors (SVTM A Series) feature a type IC 400 construction - this means the motor is totally enclosed and does not need any kind of additional ventilation; this also allows for an IP65 degree of protection on the housing.

To ensure higher service life, most insulating materials are rated in the 200-degree class. In addition, the stator pack design with winding in the groove and using Neodymium magnets ensures high performance with small dimensions, resulting in a sinusoidal electromotive force. For enhanced application safety, a temperature sensor is mounted for each winding so as to prevent damage from overheating and consequently increasing motor service life.

Motors are tested in accordance with EN 60034-18-41 standard relating to partial discharge between windings. To increase the application range, the insulating materials used are UL certified. All our motors are available with shaft and key. Working voltage options according to customer specifications are available on request. Adjustable connectors (M23 or M17), are mounted in the motors and there may be different wiring and connector solutions.

### Benefits

High efficiency	Many feedback available
Low voltage	IP65 water resistant standard
Many customisation options	Brake option
Many voltage options available	

Product code

1 2 3 4 5 6 7  
SVTM A BB - CCC - DD - E - F - GGG

- 1 Series: A
- 2 Frame: 01 [60]; 02 [80]; 03 [115]; 04 [145]
- 3 Stall torque
- 4 BEMF
- 5 Feedback: resolver [R]; incremental encoder [E]; absolute encoder [A]
- 6 Brake: yes [1]; no [0]
- 7 Customisations

## Certifications

CE  
RoHS 2011/65/EUv

## Features

Sealing	IP65
Winding	3 phase sinusoidal
Operating temperature	-20° +40° C
Tested	EN 60034-18-41
Insulation class	F, 155° C
Thermal protection	PTC
Construction	IC 400
Adjustable connectors	M17 (frame 01) or M23
Magnets	Neodymium
Insulators	UL
Construction technology	high density fractional-slot concentrated-windings
Standard feedback	resolver, incremental encoder
Option	brake 24 VDC

### EN 60034-18-41

Partial discharge free electrical insulation systems (type 1) used in rotating electrical machines fed from voltage converters - qualification and quality control test.





# SVTM A 02

Values	Unit	SVTM A			
		02-1.74-12-x-x-000	02-1.85-36-x-x-000	02-3.00-25-x-x-000	02-3.18-57-x-x-000
Frame	□ [mm]	80	80	80	80
Motor length	L [mm]	125	125	155	155
Motor length with brake	L [mm]	166	166	203	203
Continous stall torque	To [Nm]	+1,74	1,85	3	3,18
Continous stall current	Io [Arms]	9	3,3	7,7	3,55
Peak torque	Tpk [Nm]	6,3	6,3	11,5	11,5
Peak current	Ipk [Arms]	38,7	13,3	34,3	14,9
Constant torque	Kt [Nm/Arms]	0,196	0,57	0,388	0,895
Constant BEMF (1)(2)	Ke [Vrms/krpm]	12,5	36,4	25	57,6
Resistance (1)(2)	R [Ohm]	0,6	4,4	0,92	4,35
Inductance (1)	L [mH]	1,45	13,3	2,9	14,8
Rotor inertia	J [kgcm <sup>2</sup> ]	0,8	0,8	1,5	1,5
Max. axial load	Fa [N]	110	110	110	110
Max. radial load	Fr [N]	330	330	330	330
Insualtion class		F, 155°C	F, 155°C	F, 155°C	F, 155°C
Ambient temperature (3)	Ta [°C]	-20 +40	-20 +40	-20 +40	-20 +40
Protection degree	shaft exit excl.	IP65	IP65	IP65	IP65
Mass	W [kg]	1,3	1,3	1,6	1,6
Thermal protection		PTC	PTC	PTC	PTC

Values	Unit	SVTM A	
		02-4.10-37-x-x-000	02-4.39-77-x-x-000
Frame	□ [mm]	80	80
Motor length	L [mm]	185	185
Motor length with brake	L [mm]	233	233
Continous stall torque	To [Nm]	4,1	4,39
Continous stall current	Io [Arms]	7,1	3,67
Peak torque	Tpk [Nm]	16,3	16,3
Peak current	Ipk [Arms]	32,8	16
Constant torque	Kt [Nm/Arms]	0,58	1,196
Constant BEMF (1)(2)	Ke [Vrms/krpm]	37,5	77
Resistance (1)(2)	R [Ohm]	1,25	4,6
Inductance (1)	L [mH]	3,7	17,4
Rotor inertia	J [kgcm <sup>2</sup> ]	2,25	2,25
Max. axial load	Fa [N]	110	110
Max. radial load	Fr [N]	330	330
Insualtion class		F, 155°C	F, 155°C
Ambient temperature (3)	Ta [°C]	-20 +40	-20 +40
Protection degree	shaft exit excl.	IP65	IP65
Mass	W [kg]	1,3	1,3
Thermal protection		PTC	PTC

(1) Line-line

(2) At 20° C

(3) With no condansation

Note: Rated values are calculated at 20°C ambient temperature with an heat sink size of 254x254x6.35 mm

## Feedback

Resolver (Standard)

Incremental encoder with hall (standard)

Absolute feedback (on request)

## Customisation

Shaft with key Low voltage winding (24-48 VDC), others available on request

Specific connectors Feedback

Specific resolver phasing

Thermal protection type on request

All dimensions in millimeters, unless otherwise specified

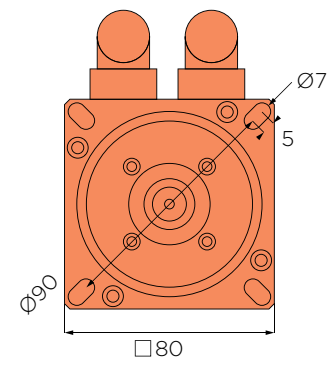
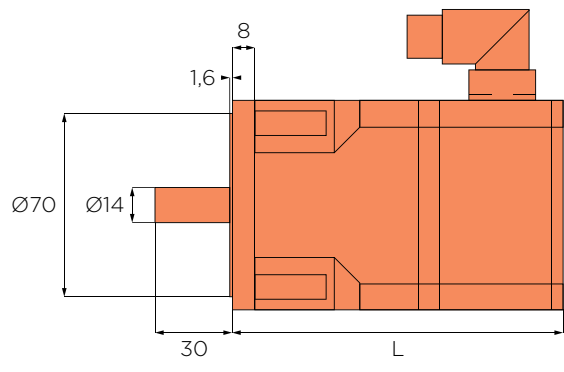
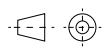

SVTM A 02

SVTM A 02-1.74-12

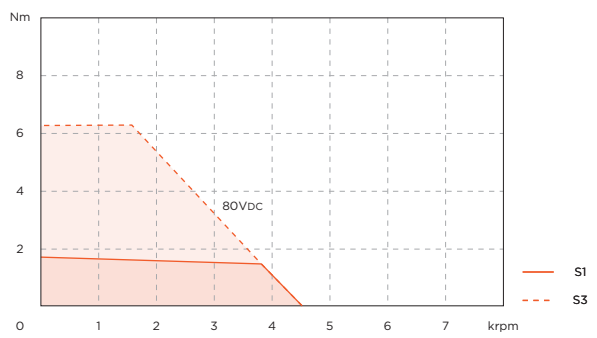

SVTM A 02-1.85-36

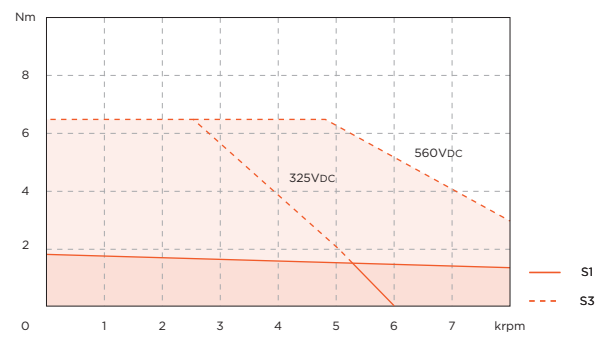

SVTM A 02-3.18-57

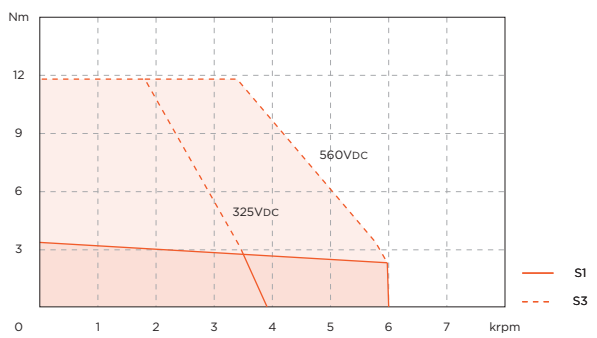

SVTM A 02-3.00-25

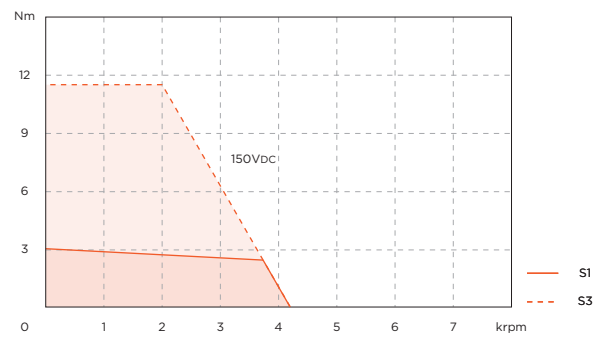

SVTM A 02-4.10-37

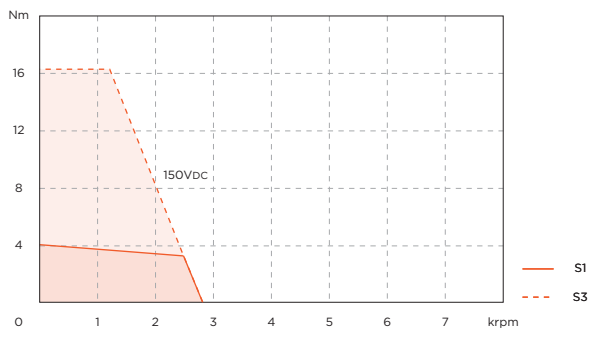

SVTM A 02-4.39-77

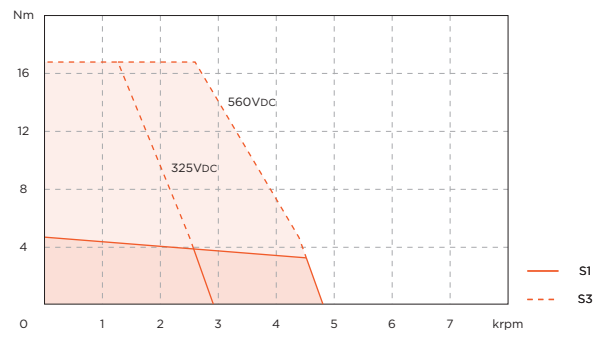

**Note:**

Rated values are calculated at 20°C ambient temperature with an heat sink size of 254x254x6.35 mm.

All dimensions in millimeters, unless otherwise specified

# SVTM A 03

Values	Unit	SVTM A			
		03-4.90-61-x-x-000	03-8.60-105-x-x-000	03-11.5-107-x-x-000	03-14.4-120-x-x-000
Frame	□ [mm]	115	115	115	115
Motor length	L [mm]	156	187	218	249
Motor length with brake	L [mm]	204	235	270	301
Continous stall torque	To [Nm]	4,9	8,6	11,5	14,4
Continous stall current	Io [Arms]	5,1	5,25	6,85	7,7
Peak torque	Tpk [Nm]	12	22	30	38
Peak current	Ipk [Arms]	15,5	15,8	21	23,3
Constant torque	Kt [Nm/Arms]	0,956	1,64	1,68	1,87
Constant BEMF (1)(2)	Ke [Vrms/krpm]	61,6	105,6	107	120,5
Resistance (1)(2)	R [Ohm]	2,6	2,95	1,86	1,59
Inductance (1)	L [mH]	12,7	18,7	12,8	12,1
Rotor inertia	J [kgcm <sup>2</sup> ]	3,7	7,2	10,8	14,4
Max. axial load	Fa [N]	210	210	210	210
Max. radial load	Fr [N]	630	630	630	630
Insualtion class		F, 155°C	F, 155°C	F, 155°C	F, 155°C
Ambient temperature (3)	Ta [°C]	-20 +40	-20 +40	-20 +40	-20 +40
Protection degree	shaft exit excl.	IP65	IP65	IP65	IP65
Mass	W [kg]	4	6,5	9,5	12,5
Thermal protection		PTC	PTC	PTC	PTC

(1) Line-line

(2) At 20° C

(3) With no condansation

Note: Rated values are calculated at 20°C ambient temperature with an heat sink size of 305x305x12,7 mm

## Feedback

Resolver (Standard)

Incremental encoder with hall (standard)

Absolute feedback (on request)

## Customisation

Shaft with key

Low voltage winding (24-48 VDC), others available on request

Specific connectors

Feedback

Specific resolver phasing

Thermal protection type on request

All dimensions in millimeters, unless otherwise specified



# SVTM A 04

Values	Unit	SVTM A			
		04-12.2-82-x-x-000	04-16.8-110-x-x-000	04-21.0-107-x-x-000	04-24.3-88-x-x-000
Frame	□ [mm]	145	145	145	145
Motor length	L [mm]	175	200	225	250
Motor length with brake	L [mm]	227	252	283	308
Continous stall torque	To [Nm]	12,2	16,8	21	24,3
Continous stall current	Io [Arms]	9,6	9,9	12,8	17,8
Peak torque	Tpk [Nm]	30,1	42,6	54,1	63,7
Peak current	Ipk [Arms]	28,7	29,7	38,4	53,3
Constant torque	Kt [Nm/Arms]	1,28	1,71	1,66	1,38
Constant BEMF (1)(2)	Ke [Vrms/krpm]	82,1	110	107	88,8
Resistance (1)(2)	R [Ohm]	1,05	1,09	0,71	0,42
Inductance (1)	L [mH]	10,5	12	8,5	4,7
Rotor inertia	J [kgcm <sup>2</sup> ]	14	20,75	27,5	34,25
Max. axial load	Fa [N]	430	430	430	430
Max. radial load	Fr [N]	1300	1300	1300	1300
Insualtion class		F, 155°C	F, 155°C	F, 155°C	F, 155°C
Ambient temperature (3)	Ta [°C]	-20 +40	-20 +40	-20 +40	-20 +40
Protection degree	shaft exit excl.	IP65	IP65	IP65	IP65
Mass	W [kg]	10	12,2	14,4	16,6
Thermal protection		PTC	PTC	PTC	PTC

(1) Line-line

(2) At 20° C

(3) With no condansation

Note: Rated values are calculated at 20°C ambient temperature with an heat sink size of 457x457x12,5 mm

## Feedback

Resolver (Standard)

Incremental encoder with hall (standard)

Absolute feedback (on request)

## Customisation

Shaft with key

Low voltage winding (24-48 VDC), others available on request

Specific connectors

Feedback

Specific resolver phasing

Thermal protection type on request

All dimensions in millimeters, unless otherwise specified



# SVTM B Series

## Synchronous Motors





# SVTM B Series

## Synchronous Motors



CUSTOMISABLE



COST-EFFECTIVE



HIGH POWER

Synchronous Motors are distinguished by ease of use; in fact, while being Brushless motors, therefore not subject to brush maintenance, they do not require drivers or controllers for operation. Our motors are available for both the 220VAC voltage and 50Hz frequency markets, and the 110Vac voltage and 60Hz frequency markets.

Furthermore, the construction motor allows operating current to be equal to start current as well as having high dynamics in a start-stop operation.

Another distinctive feature of Synchronous motors is being able to obtain the stall torque of the locked rotor by applying a DC voltage; even in this condition, if the motor operates within its nominal parameters, there will be no overheating problems.

The motor is supplied with a free-wire solution but, as an option, you can have a terminal box in a hood mounted on the rear flange.

### Benefits

- Compact
- Easy to use
- Customisable
- Cost-effective

Product code

1 2 3 4 5 6 7  
SVTM B BB - CCC - DDD - E - F - GGG

- 1 Series: B
- 2 Frame: 01 [82]
- 3 Synchronous torque
- 4 Operating voltage
- 5 Options: single [S]; double [D]; double [D]; terminal box with PG13,5 [M]; terminal box with 3/8gas [I]
- 6 Brake: no [0]
- 7 Customisations

## Certifications

CE

RoHS 2011/65/EU

## Features

Winding	three-phase synchronous motor
Operating temperature	-20° +40° C
Insulation class	B, 130°C
Magnets	Neodymium
Operation	bidirectional

# SVTM B 01

Values	Unit	SVTM B		
		01-0.90-220-x-0-000	01-0.90-120-x-0-000	01-01.4-220-x-0-000
Frame	Ø [mm]	82	82	82
Length	L [mm]	65	65	65
Synchronous max torque	To [Nm]	0,9	0,9	1,4
Operating voltage	VAC	220	120	220
Operating frequency	Hz	50	60	50
Nominal speed	Nn [rpm]	60	72	60
Rotor inertia	J [kgcm <sup>2</sup> ]	0,65	0,65	0,65
Mass	W [kg]	1,5	1,5	1,5
Ambient temperature (1)	Ta [°C]	-20 +40	-20 +40	-20 +40
Insulation class		B, 130°C	B, 130°C	B, 130°C
Suggested phase shift component				
Resistor	Ohm	750	470	400
	Watt	100	100	100
Capacitor	microF	0,8	2	2,5
	VAC	400	400	400

Values	Unit	SVTM B		
		01-1.40-120-x-0-000	01-1.70-220-x-0-000	01-1.70-120-x-0-000
Frame	Ø [mm]	82	82	82
Length	L [mm]	65	92	92
Synchronous max torque	To [Nm]	1,4	1,7	1,7
Operating voltage	VAC	120	220	120
Operating frequency	Hz	60	50	60
Nominal speed	Nn [rpm]	72	60	72
Rotor inertia	J [kgcm <sup>2</sup> ]	0,65	1,2	1,2
Mass	W [kg]	1,5	2,5	2,5
Ambient temperature (1)	Ta [°C]	-20 +40	-20 +40	-20 +40
Insulation class		B, 130°C	B, 130°C	B, 130°C
Suggested phase shift component				
Resistor	Ohm	200	820	300
	Watt	100	100	100
Capacitor	microF	6,3	1,6	4
	VAC	400	400	400

Values	Unit	SVTM B		
		01-2.60-120-x-0-000	01-3.20-220-x-0-000	01-3.20-120-x-0-000
Frame	Ø [mm]	82	82	82
Length	L [mm]	129	129	129
Synchronous max torque	To [Nm]	2,6	3,2	3,2
Operating voltage	VAC	120	220	120
Operating frequency	Hz	60	50	60
Nominal speed	Nn [rpm]	72	60	72
Rotor inertia	J [kgcm <sup>2</sup> ]	1,9	1,9	1,9
Mass	W [kg]	3,7	3,7	3,7
Ambient temperature (1)	Ta [°C]	-20 +40	-20 +40	-20 +40
Insulation class		B, 130°C	B, 130°C	B, 130°C
Suggested phase shift component				
Resistor	Ohm	300	500	100
	Watt	100	100	100
Capacitor	microF	6,5	2,5	8
	VAC	400	400	400

(1) With no condensation

## Customisation

Wire drawing flange

Wire length

Wire drawing shaft

Terminal box connection

Brake

Encoder

All dimensions in millimeters, unless otherwise specified

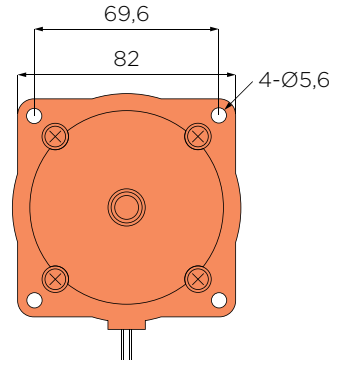
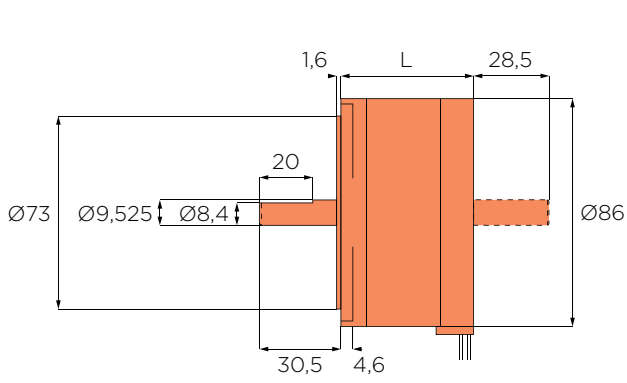
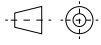

SVTM B 01

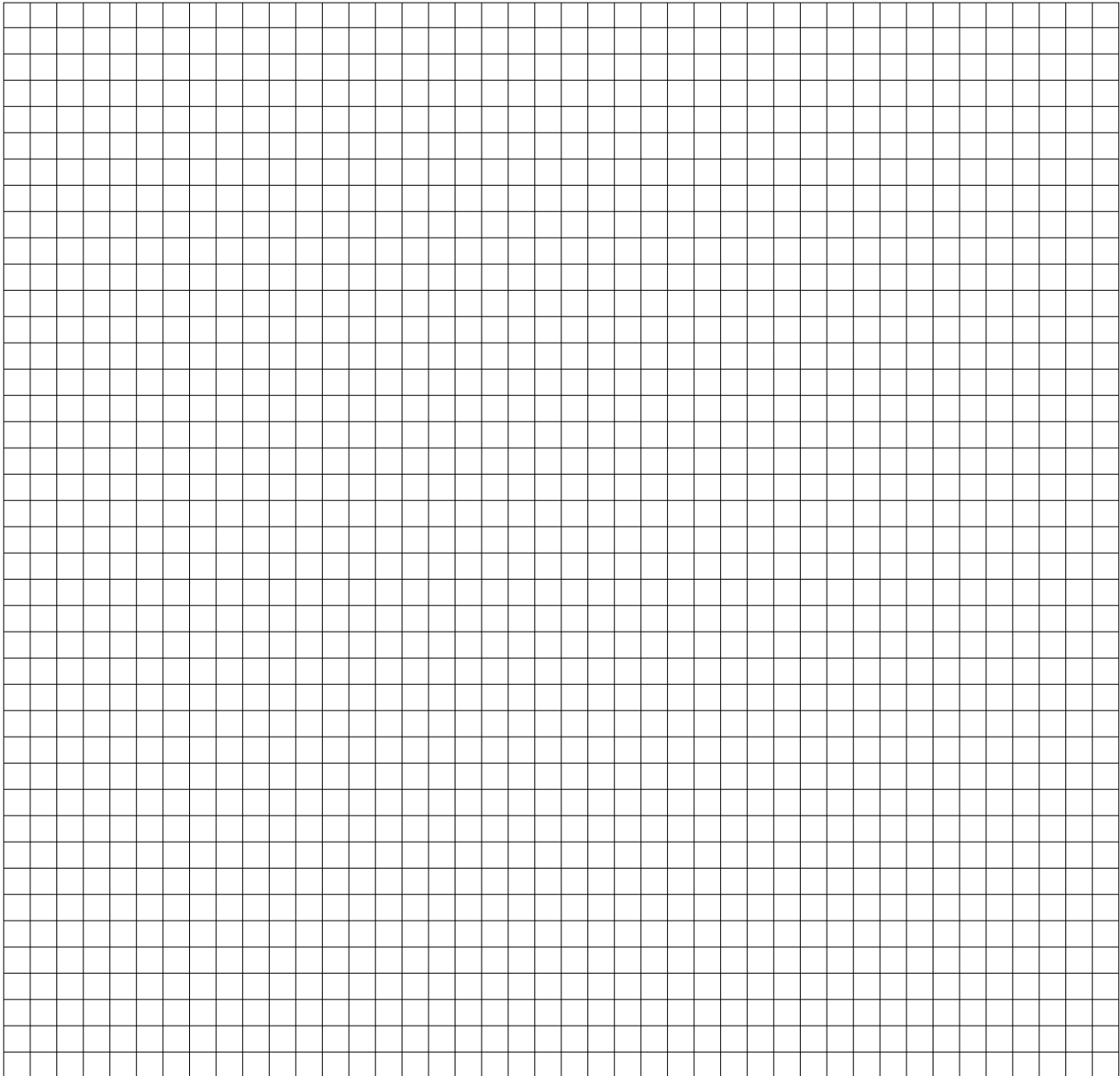

All dimensions in millimeters, unless otherwise specified



# SVTM C Series

## Stepper Motors





# SVTM C Series

## Stepper Motors



COST-EFFECTIVE



STURDY



HIGH TORQUE

The Stepper Motors of the SVTM C 01 family feature a two-phase electromagnetic design which has, however, a four-phase configuration option that ensures compatibility with most drivers on the market. The characteristic design allows for a small-sized rotor and, combined with high-energy magnets, a thorough production process ensuring a reduced airgap and consequently higher dynamics.

Stepper motors of the SVTMC 02 and C 03 families are characterised by a two-phase electromagnetic design ensuring compatibility with the most drivers on the market. Their specific design allows for a large-sized rotor and, thanks to high-energy magnets and a thorough production process, ensures a reduced airgap and higher torques. Moreover, a high-inertia rotor makes it possible to have better speed linearity compared to conventional Stepper Motors.

Their unique design allows for very low values of the detent torque harmonic spectrum in addition to excellent performance even in micro-stepping mode. Torque linearity allows overloading the motor for the toughest applications. The housing structure completely made of aluminium alloy, along with high-quality insulating materials, ensures sturdiness and reliability. The high construction standards allow for very reduced shaft and pilot ring runout tolerances (shaft runout 0.051, pilot ring runout 0.077, pilot ring perpendicularity 0.077), thus allowing coupling with gearboxes.

### Benefits

Cost effective	Customisable
Easy to use	Sturdy





Product code

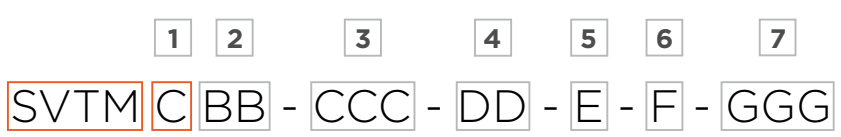

- 1 Series: C
- 2 Frame: 01 [82]; 02 [92]; 03 [115]
- 3 Holding torque
- 4 Rated current
- 5 Shaft: single [S]; double [D]; terminal box with PG13,5 [M]\*; terminal box with 3/8gas [I]\*
- 6 Brake: no [0]
- 7 Customisations: 8 wires connection [8xx]\*

\* SVTM C 01 only

## Certifications

CE  
RoHS 2011/65/EU

## Features

Winding	bi-phase stepper motor
Operating temperature	-20° +40° C
Insulation class	B, 130°C
Magnets	Neodymium
Housing	Aluminium for SVTM C 02 and D 03 series
Shaft runout	0.051 for SVTM C 02 and C 03
Pilot ring oscillation	0.077 for SVTM C 02 and C 03
Pilot ring perpendicularity	0.077 for SVTM C 02 and C 03
Connection	Free lead
Step angle	1.8°

# SVTM C 01

4 WIRES	Values	Unit	SVTM C			
			01-2.8-02-x-0-000	01-2.8-04-x-0-000	01-2.8-06-x-0-000	01-4.8-04-x-0-000
Frame	Ø [mm]		82	82	82	82
Length	L [mm]		65	65	65	92
Rated current	[Arms]		2	4	6	4
Holding torque	[Nm]		2,8	2,8	2,8	4,8
Phase resistance	[Ohm]		2,5	0,65	0,28	0,85
Phase inductance	[mH]		21	5,1	2,1	7,7
Rotor inertia	J [kgm <sup>2</sup> x10 <sup>-3</sup> ]		0,065	0,065	0,065	0,12
Mass	W [kg]		1,5	1,5	1,5	2,5
Insulation class			B, 130°C	B, 130°C	B, 130°C	B, 130°C
Ambient temperature (1)	Ta [°C]		-20 +40	-20 +40	-20 +40	-20 +40
8 WIRES	Values	Unit	SVTM C			
			01-4.8-06-x-0-000	01-7.2-05-x-0-000	01-7.2-09-x-0-000	
Frame	Ø [mm]		82	82	82	
Length	L [mm]		92	129	129	
Rated current	[Arms]		6	5	9	
Holding torque	[Nm]		4,8	7,2	7,2	
Phase resistance	[Ohm]		0,37	0,75	0,25	
Phase inductance	[mH]		3,5	8,5	2,5	
Rotor inertia	J [kgm <sup>2</sup> x10 <sup>-3</sup> ]		0,12	0,18	0,18	
Mass	W [kg]		2,5	3,5	3,5	
Insulation class			B, 130°C	B, 130°C	B, 130°C	
Ambient temperature (1)	Ta [°C]		-20 +40	-20 +40	-20 +40	
8 WIRES	Values	Unit	SVTM C			
			01-2.8-01-x-0-800	01-2.8-02-x-0-800	01-2.8-04-x-0-800	01-4.8-02-x-0-800
Frame	Ø [mm]		82	82	82	82
Length	L [mm]		65	65	65	92
Rated current	[Arms]		1,4	2,8	4,3	2,8
Holding torque	[Nm]		2,8	2,8	2,8	4,8
Phase resistance	[Ohm]		5	1,3	0,56	1,17
Phase inductance	[mH]		21	5,1	2,1	7,7
Rotor inertia	J [kgm <sup>2</sup> x10 <sup>-3</sup> ]		0,065	0,065	0,065	0,12
Mass	W [kg]		1,5	1,5	1,5	2,5
Insulation class			B, 130°C	B, 130°C	B, 130°C	B, 130°C
Ambient temperature (1)	Ta [°C]		-20 +40	-20 +40	-20 +40	-20 +40
8 WIRES	Values	Unit	SVTM C			
			01-4.8-04-x-0-800	01-3.5-03-x-0-800	01-7.2-06-x-0-800	
Frame	Ø [mm]		82	82	82	
Length	L [mm]		92	129	129	
Rated current	[Arms]		4,3	3,5	6,4	
Holding torque	[Nm]		4,8	6	7,2	
Phase resistance	[Ohm]		0,75	1,5	0,5	
Phase inductance	[mH]		3,5	8,5	2,5	
Rotor inertia	J [kgm <sup>2</sup> x10 <sup>-3</sup> ]		0,12	0,18	0,18	
Mass	W [kg]		2,5	3,5	3,5	
Insulation class			B, 130°C	B, 130°C	B, 130°C	
Ambient temperature (1)	Ta [°C]		-20 +40	-20 +40	-20 +40	

(1) With no condensation

Note: Rated values are calculated at 20°C ambient temperature

## Customisation

Wire drawing flange	Wire length
Wire drawing shaft	Winding: Four-phase
Brake	Other voltage winding
Encoder	

All dimensions in millimeters, unless otherwise specified











# SVTM D Series

## Brush Torque Motors





# SVTM D Series

## Brush Torque Motors



LIGHTWEIGHT

CUSTOMISABLE

HIGH POWER

DC Torque Motors operate on the same principles as the conventional DC motors but the magnetic circuit design and consequent mechanical configuration are designed for a maximum torque output rather than the usual low torque / high speed characteristic.

A range of unoused units are supplied as three separate components, a permanent magnet field assembly, a wound armature with precision bore for mounting and a brush ring assembly or brush segments.

A fixed element - the stator, is equipped with rare earth permanent magnets and the rotor is equipped with a dc specific winding which is connected to an extra flat commutator - brushed system. Low speed Torque Motors are beneficial for direct-drive applications. Position and speed feedback can be achieved via additions of DC Tachos, Resolvers or Optical Encoders.

The unoused motors described below can be supplied in custom designed housings for specific applications.

### Benefits

Compact	Wide range
Easy to use	Integrable into the mechanics
Customisable	Extended operating temperatures

F 02058 - 78 28 00 - 49  
info@wagnergmbh.de  
www.wagnergmbh.de

Robert-Bosch-Straße 35  
42489 Wülfrath  
T. 02058 - 78 28 00 - 0

Product code

1   2   3   4   5  
SVTM D BB - CCC - DD - EEE

- 1 Series: D
- 2 Frame: 01 [38.1]; 02 [51]; 03 [60.32]; 04 [76.2]; 05 [85.725]; 06 [92.075]; 07 [114.3]; 08 [130.175]
- 3 Stall torque
- 4 Voltage
- 5 Customisations

## Certifications

RoHS 2011/65/EU

## Features

Winding	brush two-phase DC motor
Operating temperature	-40° +70° C
Insulation class	F, 155° C for 01-04 model and 08 or H, 180° C for 05-07 model
Magnets	rare earth
Collector	gold plating
Construction technology	frameless
Wire length	300mm

F 02058 - 78 28 00 - 49  
 info@wagnergmbh.de  
 www.wagnergmbh.de

Robert-Bosch-Straße 35  
 42489 Wülfrath  
 T 02058 - 78 28 00 - 0

# SVTM D 01

Values	Unit	SVTM D		
		01-0,07-18-000	01-0,12-23-000	01-0,14-17-000
Frame	Ø [mm]	38,1	38,1	38,1
Motor length	L [mm]	9,78	12,95	12,95
Peak torque, stalled @Vp	Tp [mNm]	77,7	127	141
Power input @Tp	P [W]	56,7	83,3	78
Motor constant	Km [mNm/W <sup>1/2</sup> ]	10,3	13,9	16
Electrical time constant	Te [ms]	0,11	0,15	0,207
No load speed @Vp	No [rpm]	6962	6961	5280
Break away torque	Tf [mNm]	4,24	2,2	4,94
Ripple torque	Tr [% avg to peak]	7	5	7
Max allowable temperate/insulation class		F, 155 °C	F, 155 °C	F, 155 °C
Thermal resitance	tpr [°C/W]	25	19	19
Mass	W [g]	46,8	62	65,2
Rotor inertia	J [kgm <sup>2</sup> x10 <sup>-6</sup> ]	2,97	4,24	4,24
Resistance (1)(2)	R [Ohm]	5,9	6,8	4,1
Inductance (1)	L [mH]	0,65	1,3	0,85
Torque constant	Kt [mNm/A]	25,1	36,3	32,4
BEMF constant (1)(2)	Ke [V/rad/s]	0,0251	0,0363	0,0324
Peak voltage @ Tp	Vp [V]	18,3	23,8	17,9
Peak current @ Tp	Ip [A]	3,1	3,5	4,36
Wires length	mm	300	300	300
Ambient temperature (3)	Ta [°C]	-40 +70	-40 +70	-40 +70
Values	Unit	SVTM D		
		01-0,39-22-000	01-0,35-22-000	01-0,33-18-000
Frame	Ø [mm]	38,1	38,1	38,1
Motor length	L [mm]	27,94	27,94	26
Peak torque, stalled @Vp	Tp [mNm]	395	353	333
Power input @Tp	P [W]	156	156	72
Motor constant	Km [mNm/W <sup>1/2</sup> ]	31,3	28,3	39,2
Electrical time constant	Te [ms]	0,41	0,41	-
No load speed @Vp	No [rpm]	3776	4226	2066
Break away torque	Tf [mNm]	5,4	5,4	18,5
Ripple torque	Tr [% avg to peak]	5	5	5
Max allowable temperate/insulation class		F, 155 °C	F, 155 °C	F, 155 °C
Thermal resitance	tpr [°C/W]	14	14	-
Mass	W [g]	142	142	140
Rotor inertia	J [kgm <sup>2</sup> x10 <sup>-6</sup> ]	9,86	9,86	8,7
Resistance (1)(2)	R [Ohm]	3,18	3,18	4,5
Inductance (1)	L [mH]	1,3	1,3	1,1
Torque constant	Kt [mNm/A]	56,4	50,4	83,2
BEMF constant (1)(2)	Ke [V/rad/s]	0,0564	0,0504	0,0832
Peak voltage @ Tp	Vp [V]	22,3	22,3	18
Peak current @ Tp	Ip [A]	7	7	4
Wires length	mm	300	300	300
Ambient temperature (3)	Ta [°C]	-40 +70	-40 +70	-40 +70

(1) Line-line

(2) At 25° C

(3) With no condensation

Note: Rated values are calculated at 25°C ambient temperature

## Customisation

Wire drawing stator flange

Rotor bore on request

Wires length

Other voltage winding

All dimensions in millimeters, unless otherwise specified

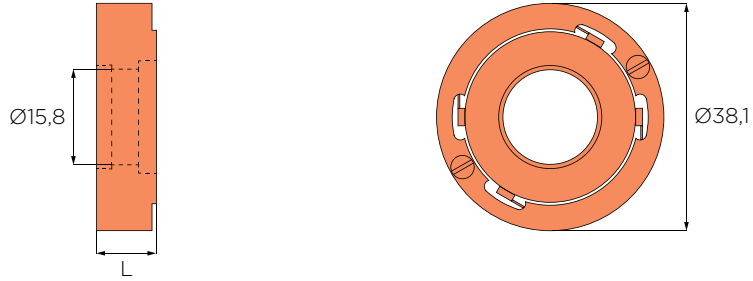
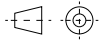

SVTM D 01

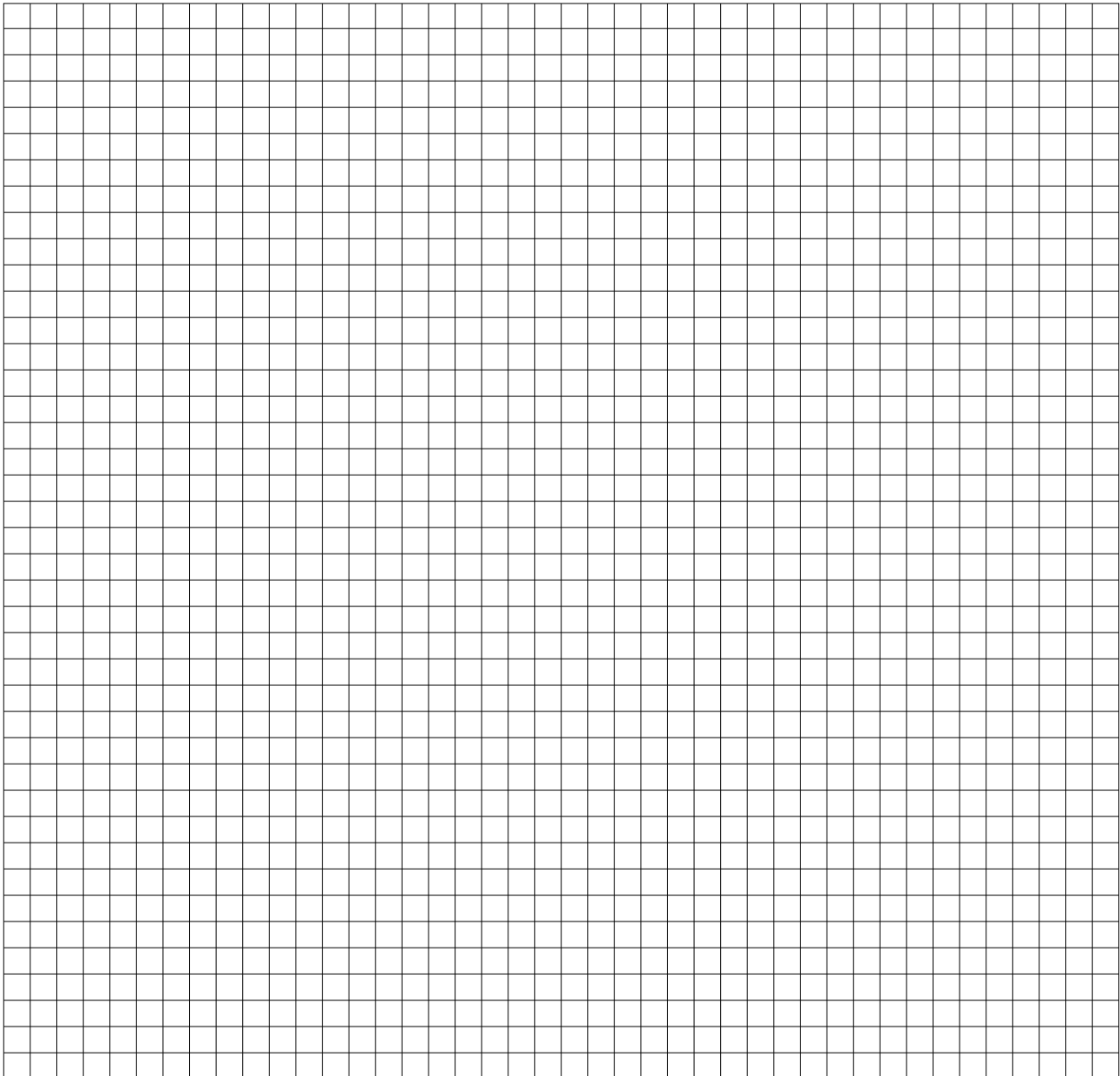

All dimensions in millimeters, unless otherwise specified





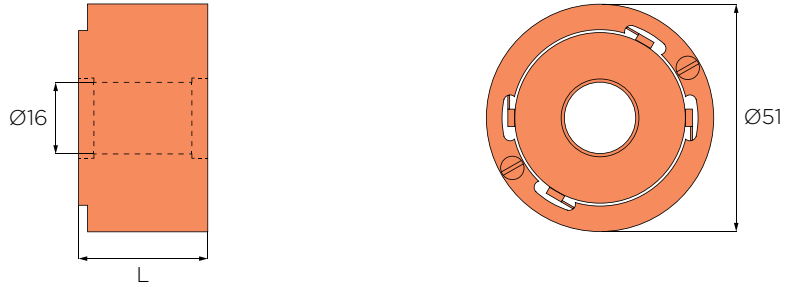
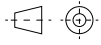

SVTM D 02

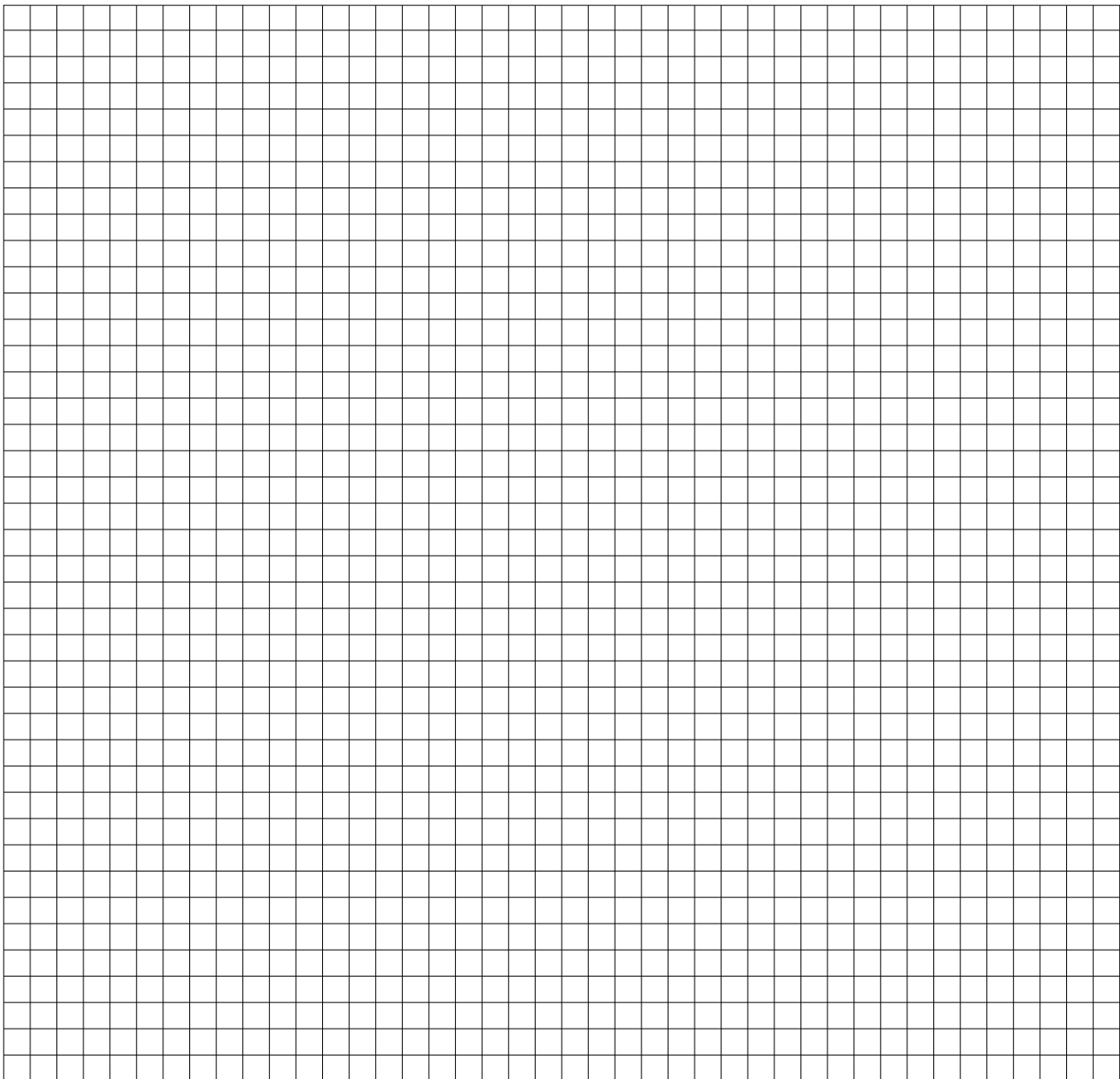

All dimensions in millimeters, unless otherwise specified





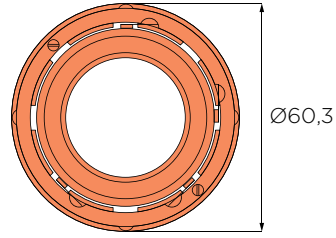
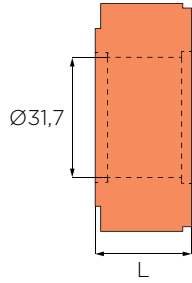
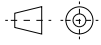

SVTM D 03

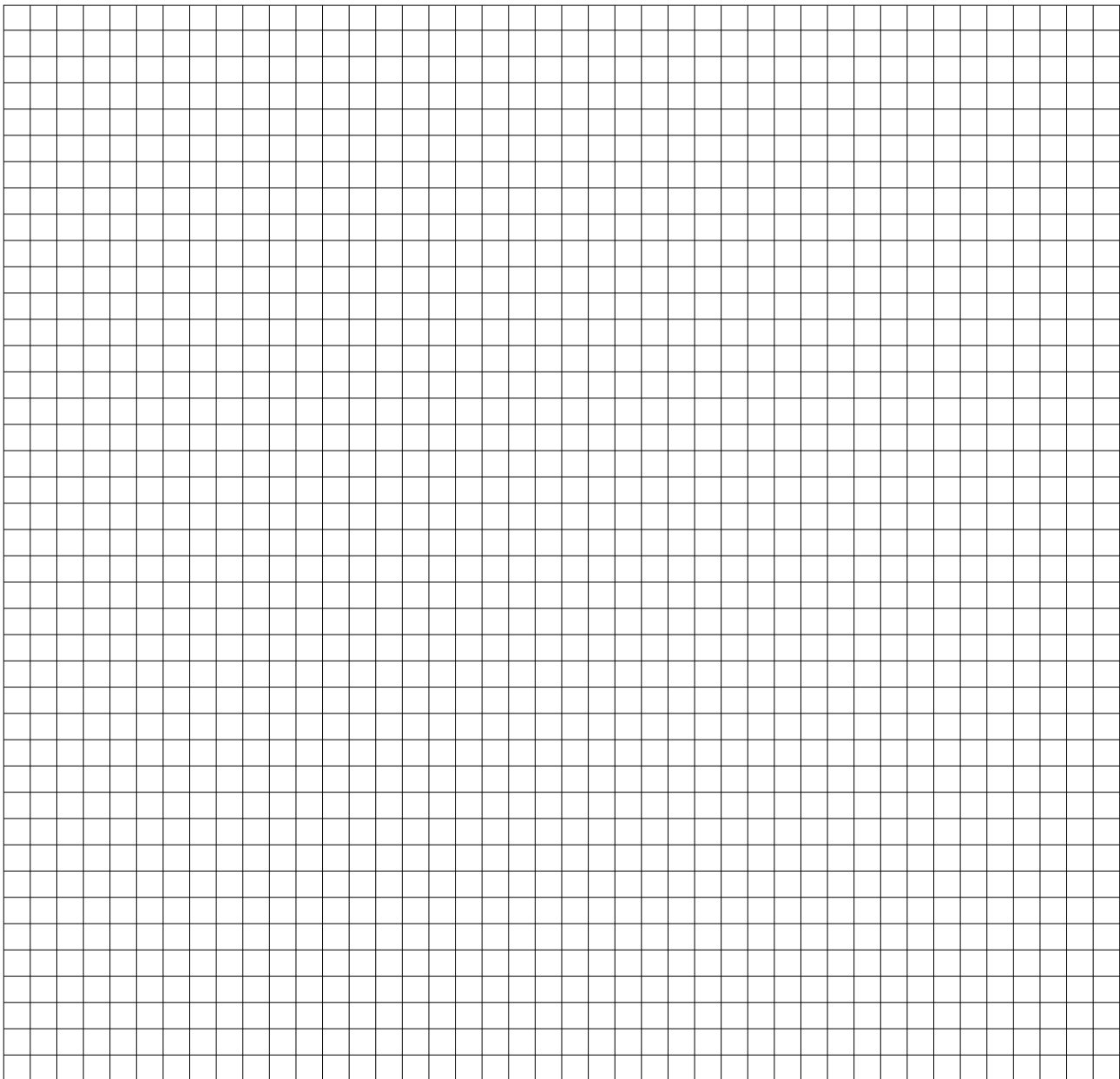

All dimensions in millimeters, unless otherwise specified





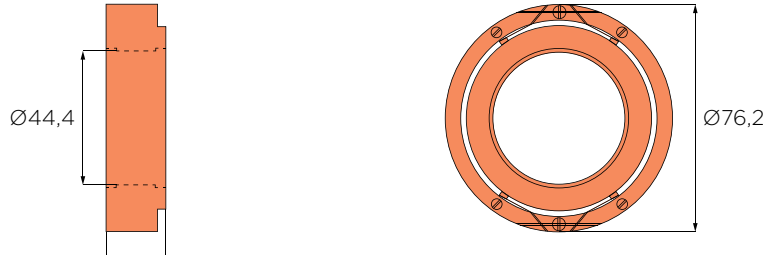
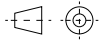

SVTM D 04

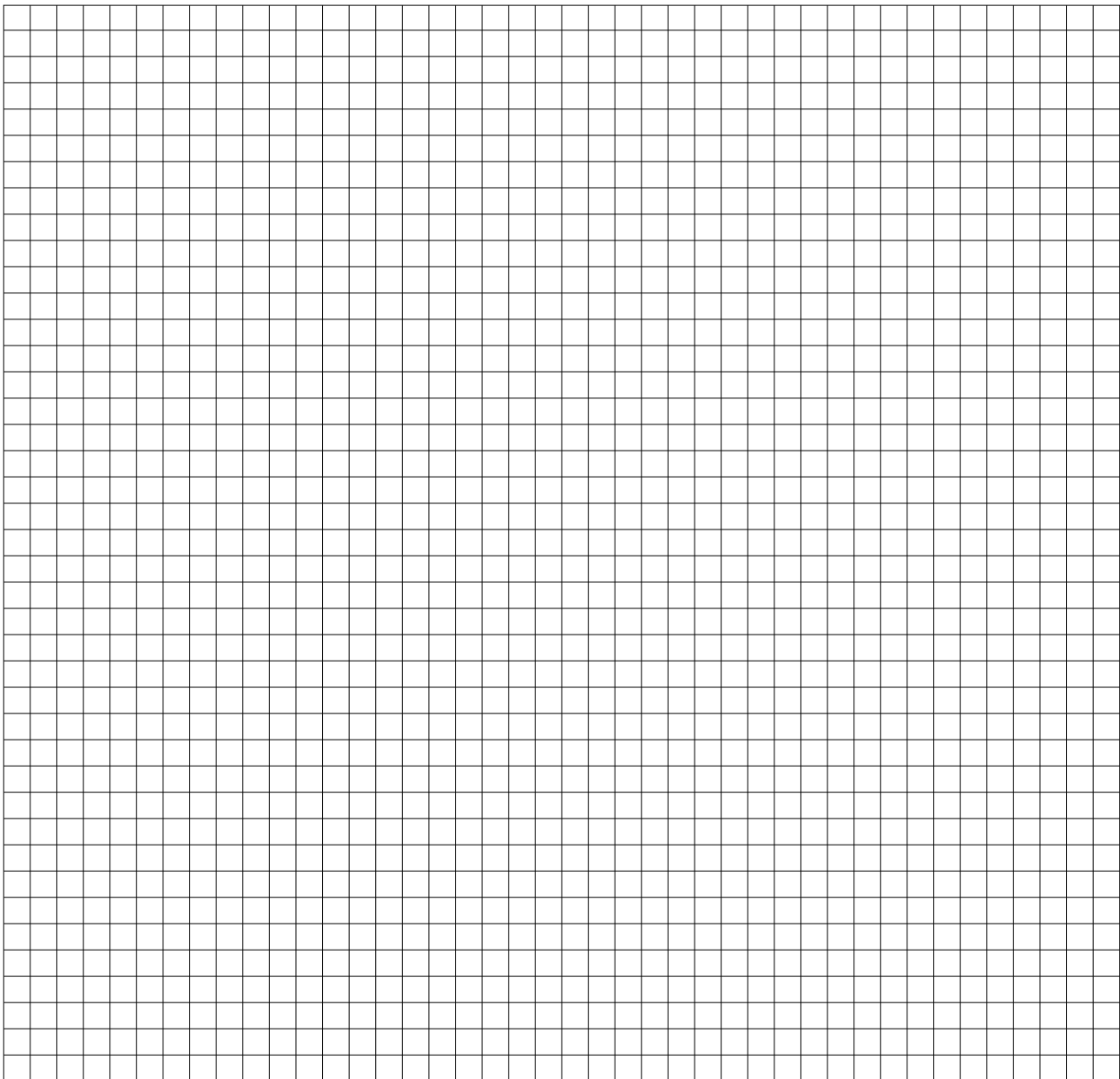

All dimensions in millimeters, unless otherwise specified





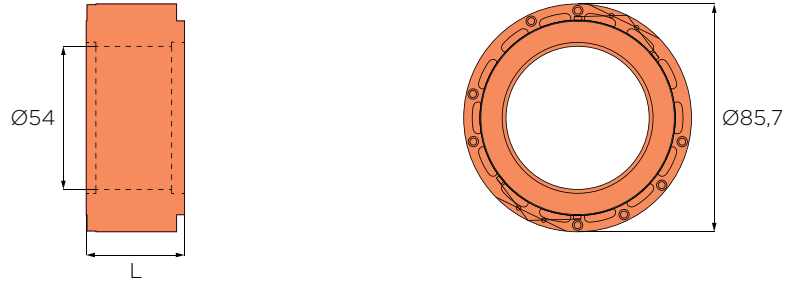
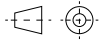

SVTM D 05

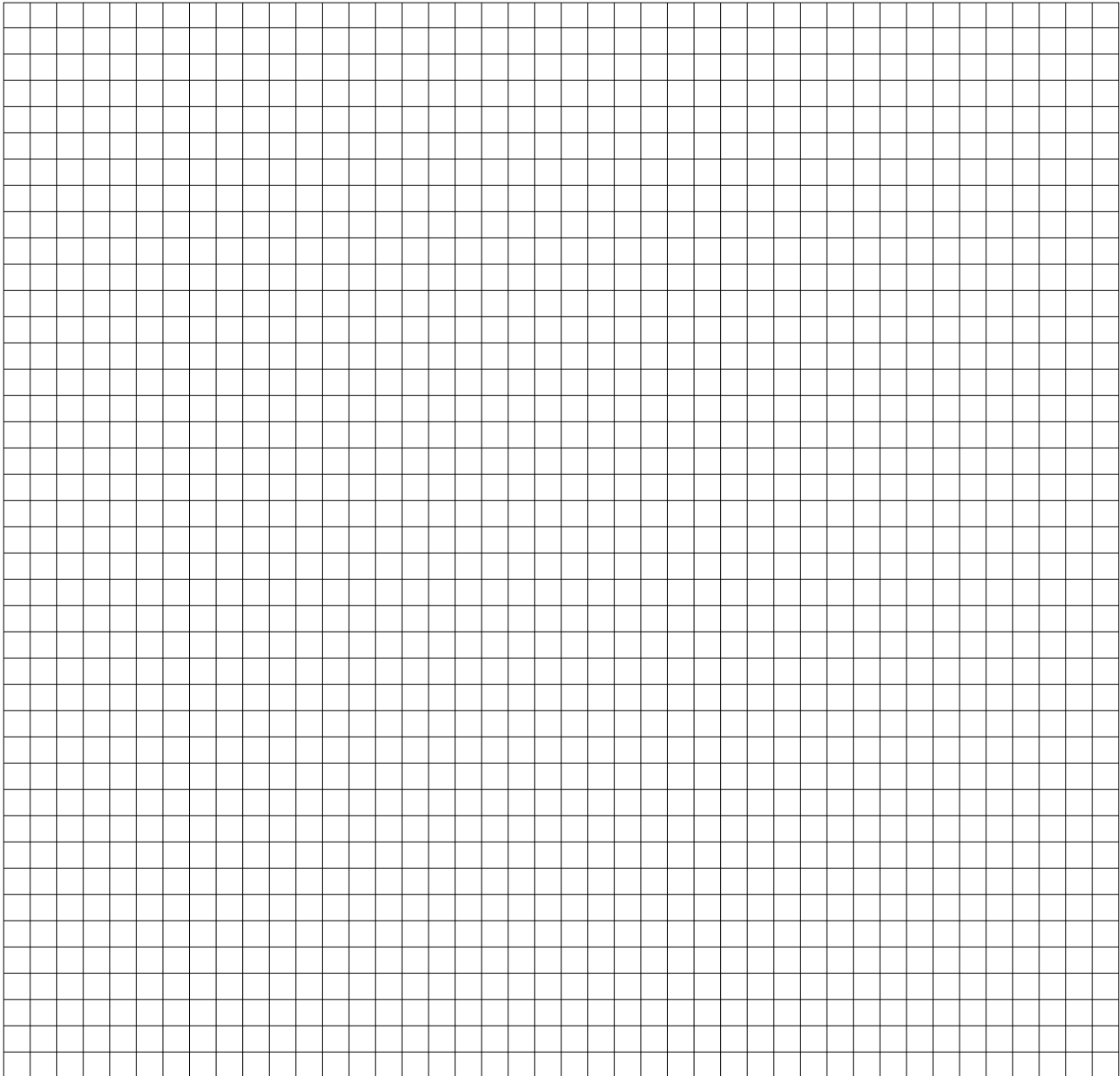

All dimensions in millimeters, unless otherwise specified



# SVTM D 06

Values	Unit	SVTM D	
		06-1,06-30-000	06-1,06-23-000
Frame	Ø [mm]	92,075	92,075
Motor length	L [mm]	13,72	13,72
Peak torque, stalled @Vp	Tp [mNm]	1060	1060
Power input @Tp	P [W]	154	154
Motor constant	Km [mNm/W <sup>1/2</sup> ]	85,4	84,4
Electrical time constant	Te [ms]	0,37	0,37
No load speed @Vp	No [rpm]	1387	1390
Break away torque	Tf [mNm]	31,8	31,8
Ripple torque	Tr [% avg to peak]	7	7
Max allowable temperate/insulation class		H, 180°C	H, 180°C
Thermal resistance	tpr [°C/W]	10,1	10,1
Mass	W [g]	241	214
Rotor inertia	J [kgm <sup>2</sup> x10 <sup>-6</sup> ]	1,61x10 <sup>-2</sup>	1,61x10 <sup>-2</sup>
Resistance (1)(2)	R [Ohm]	6,04	3,43
Inductance (1)	L [mH]	2,23	1,27
Torque constant	Kt [mNm/A]	210	158
BEMF constant (1)(2)	Ke [V/rad/s]	0,21	0,158
Peak voltage @ Tp	Vp [V]	30,5	23
Peak current @ Tp	Ip [A]	5,05	6,7
Wires length	mm	300	300
Ambient temperature (3)	Ta [°C]	-40 +70	-40 +70

Values	Unit	SVTM D	
		06-2,12-31-000	06-4,00-23-000
Frame	Ø [mm]	92,075	92,456
Motor length	L [mm]	21,33	37,008
Peak torque, stalled @Vp	Tp [mNm]	2120	4000
Power input @Tp	P [W]	284	138
Motor constant	Km [mNm/W <sup>1/2</sup> ]	0,156	0,341
Electrical time constant	Te [ms]	0,408	0,628
No load speed @Vp	No [rpm]	830	329
Break away torque	Tf [mNm]	46	130
Ripple torque	Tr [% avg to peak]	7	7
Max allowable temperate/insulation class		H, 180°C	H, 180°C
Thermal resistance	tpr [°C/W]	7,3	3,8
Mass	W [g]	430	955
Rotor inertia	J [kgm <sup>2</sup> x10 <sup>-6</sup> ]	2,8x10 <sup>-2</sup>	6,5x10 <sup>-2</sup>
Resistance (1)(2)	R [Ohm]	5,25	4
Inductance (1)	L [mH]	2,14	2,5
Torque constant	Kt [mNm/A]	358	681
BEMF constant (1)(2)	Ke [V/rad/s]	0,358	0,681
Peak voltage @ Tp	Vp [V]	31,1	23,5
Peak current @ Tp	Ip [A]	5,92	5,87
Wires length	mm	300	300
Ambient temperature (3)	Ta [°C]	-40 +70	-40 +70

(1) Line-line

(2) At 25° C

(3) With no condensation

Note: Rated values are calculated at 25°C ambient temperature

## Customisation

Wire drawing stator flange

Rotor bore on request

Wire length

Other voltage winding

All dimensions in millimeters, unless otherwise specified

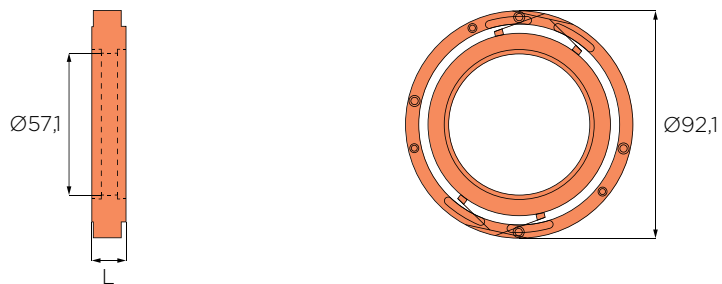

SVTM D 06

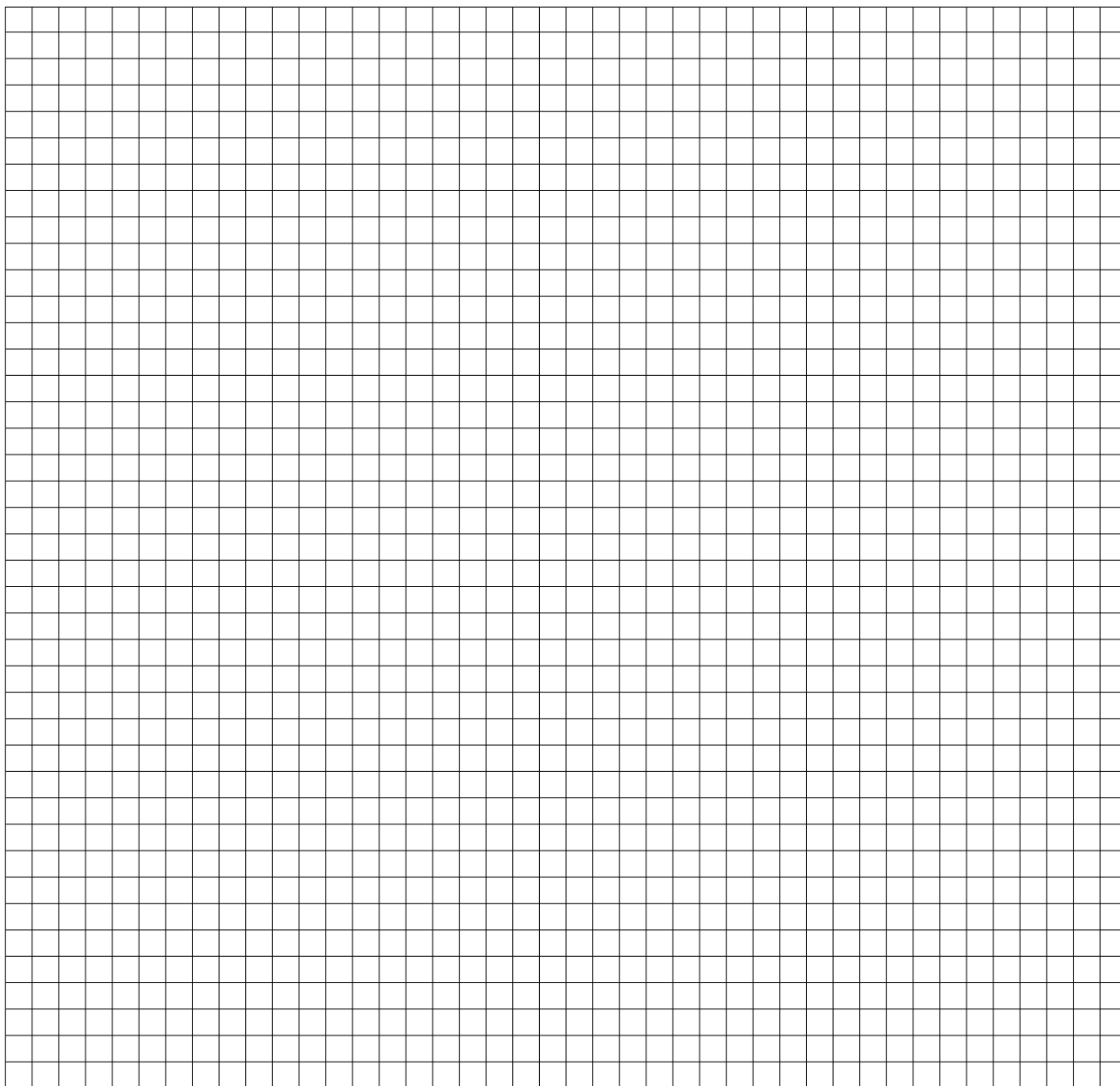

All dimensions in millimeters, unless otherwise specified



# SVTM D 07

Values	Unit	SVTM D		
		07-2,30-36-000	07-3,25-31-000	07-3,25-55-000
Frame	Ø [mm]	114,3	114,3	114,3
Motor length	L [mm]	14,22	17,45	17,45
Peak torque, stalled @Vp	Tp [mNm]	2300	3250	3250
Power input @Tp	P [W]	248	187	187
Motor constant	Km [mNm/W <sup>1/2</sup> ]	0,146	0,238	0,238
Electrical time constant	Te [ms]	0,59	0,573	0,573
No load speed @Vp	No [rpm]	1031	549	549
Break away torque	Tf [mNm]	56,5	67,8	67,8
Ripple torque	Tr [% avg to peak]	7	6	6
Max allowable temperate/insulation class		H, 180°C	H, 180°C	H, 180°C
Thermal resitance	tpr [°C/W]	6,9	3,3	3,3
Mass	W [g]	397	520	520
Rotor inertia	J [kgm <sup>2</sup> x10 <sup>-6</sup> ]	4,19x10 <sup>2</sup>	4,88x10 <sup>2</sup>	4,88x10 <sup>2</sup>
Resistance (1)(2)	R [Ohm]	5,43	5,2	16,4
Inductance (1)	L [mH]	3,19	3	9,4
Torque constant	Kt [mNm/A]	340	548	963
BEMF constant (1)(2)	Ke [V/rad/s]	0,34	0,542	0,963
Peak voltage @ Tp	Vp [V]	36,7	31,2	55,4
Peak current @ Tp	Ip [A]	6,76	6	3,38
Wires length	mm	300	300	300
Ambient temperature (3)	Ta [°C]	-40;+70	-40 +70	-40 +70

Values	Unit	SVTM D	
		07-4,59-42-000	07-6,51-33-000
Frame	Ø [mm]	114,3	114,3
Motor length	L [mm]	21,84	27,28
Peak torque, stalled @Vp	Tp [mNm]	4590	6510
Power input @Tp	P [W]	275	263
Motor constant	Km [mNm/W <sup>1/2</sup> ]	0,277	0,401
Electrical time constant	Te [ms]	0,784	0,83
No load speed @Vp	No [rpm]	573	386
Break away torque	Tf [mNm]	84,8	136
Ripple torque	Tr [% avg to peak]	7	5
Max allowable temperate/insulation class		H, 180°C	H, 180°C
Thermal resitance	tpr [°C/W]	5,2	
Mass	W [g]	697	945
Rotor inertia	J [kgm <sup>2</sup> x10 <sup>-6</sup> ]	7,19x10 <sup>2</sup>	9,76x10 <sup>2</sup>
Resistance (1)(2)	R [Ohm]	6,68	4,36
Inductance (1)	L [mH]	5,24	3,6
Torque constant	Kt [mNm/A]	715	838
BEMF constant (1)(2)	Ke [V/rad/s]	0,715	0,838
Peak voltage @ Tp	Vp [V]	42,9	33,9
Peak current @ Tp	Ip [A]	6,42	7,77
Wires length	mm	300	300
Ambient temperature (3)	Ta [°C]	-40 +70	-40 +70

(1) Line-line

(2) At 25° C

(3) With no condensation

Note: Rated values are calculated at 25°C ambient temperature

## Customisation

Wire drawing stator flange

Rotor bore on request

Wire length

Other voltage winding

All dimensions in millimeters, unless otherwise specified

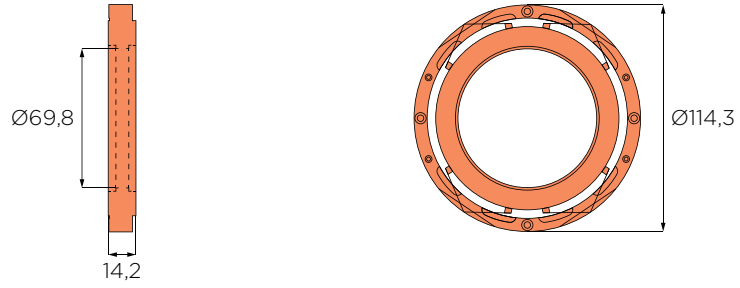
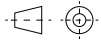

SVTM D 07

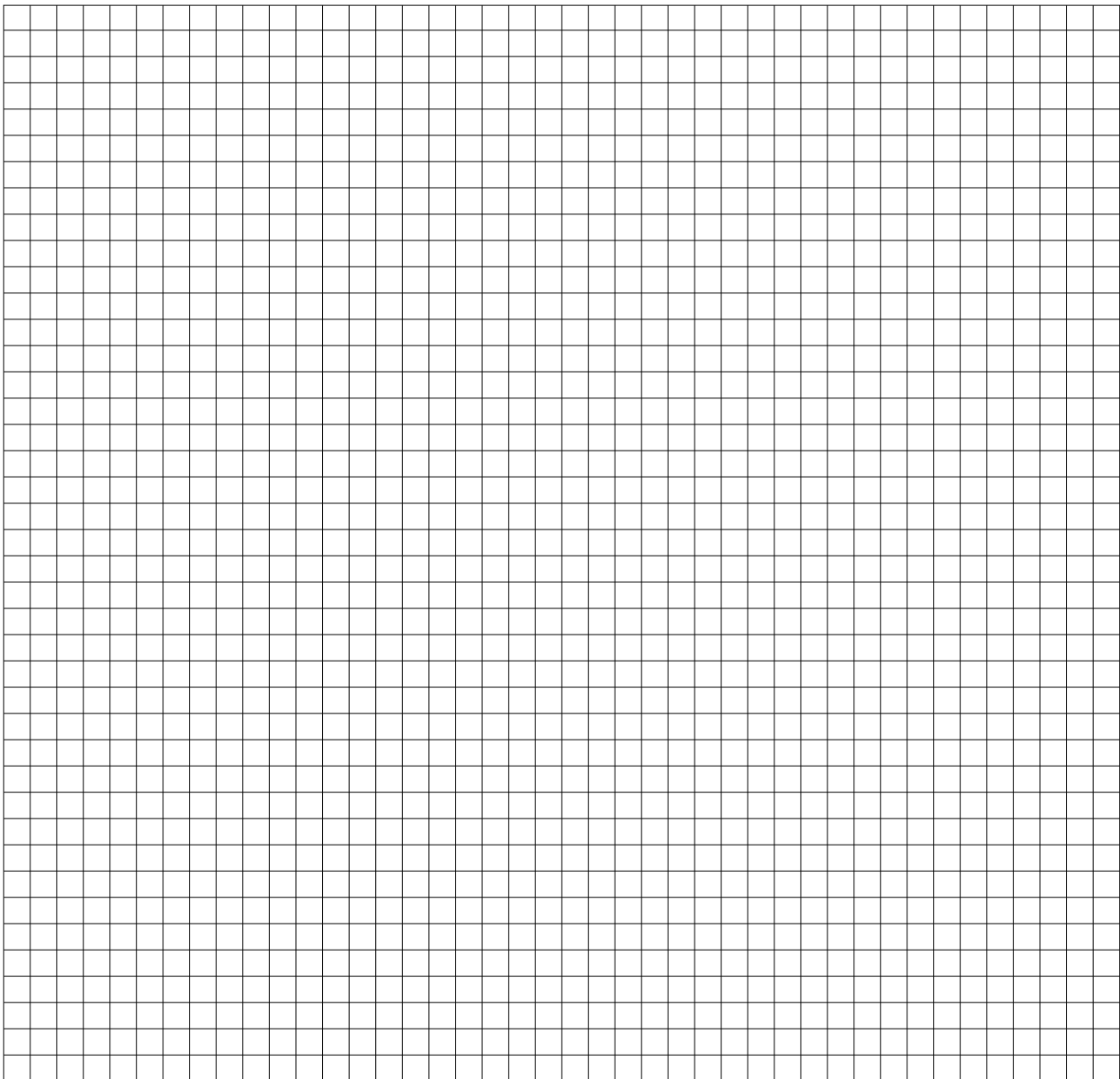

All dimensions in millimeters, unless otherwise specified



# SVTM D 08

Values	Unit	SVTM D		
		08-2,80-22-000	08-4,80-24-000	08-10,0-29-000
Frame	Ø [mm]	130,175	130,175	130,175
Motor length	L [mm]	23,9	25,5	53,34
Peak torque, stalled @Vp	Tp [mNm]	2800	4800	10000
Power input @Tp	P [W]	44	96	195
Motor constant	Km [mNm/W <sup>1/2</sup> ]	0,422	0,49	0,716
Electrical time constant	Te [ms]	0,818	0,8	1,07
No load speed @Vp	No [rpm]	150	191	186
Break away torque	Tf [mNm]	90	100	310
Ripple torque	Tr [% avg to peak]	7	7	6
Max allowable temperate/insulation class		F, 155 °C	F, 155 °C	F, 155 °C
Thermal resitance	tpr [°C/W]	2,8	2,5	0,8
Mass	W [g]	850	920	2050
Rotor inertia	J [kgm <sup>2</sup> x10 <sup>-6</sup> ]	2,1x10 <sup>3</sup>	2,25x10 <sup>3</sup>	3,18x10 <sup>3</sup>
Resistance (1)(2)	R [Ohm]	11	6	4,47
Inductance (1)	L [mH]	9	4,8	4,8
Torque constant	Kt [mNm/A]	1400	1200	1515
BEMF constant (1)(2)	Ke [V/rad/s]	1,4	1,2	1,515
Peak voltage @ Tp	Vp [V]	22	24	29,5
Peak current @ Tp	Ip [A]	2	4	6,6
Wires length	mm	300	300	300
Ambient temperature (3)	Ta [°C]	-40 +70	-40 +70	-40 +70

(1) Line-line

(2) At 25° C

(3) With no condansation

Note: Rated values are calculated at 25°C ambient temperature

## Customisation

Wire drawing stator flange

Rotor bore on request

Wire length

Other voltage winding

All dimensions in millimeters, unless otherwise specified

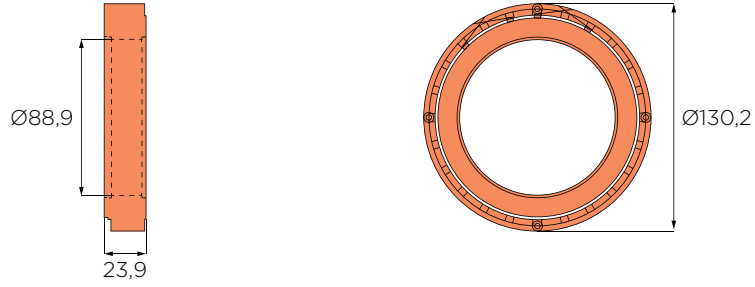
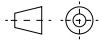

SVTM D 08

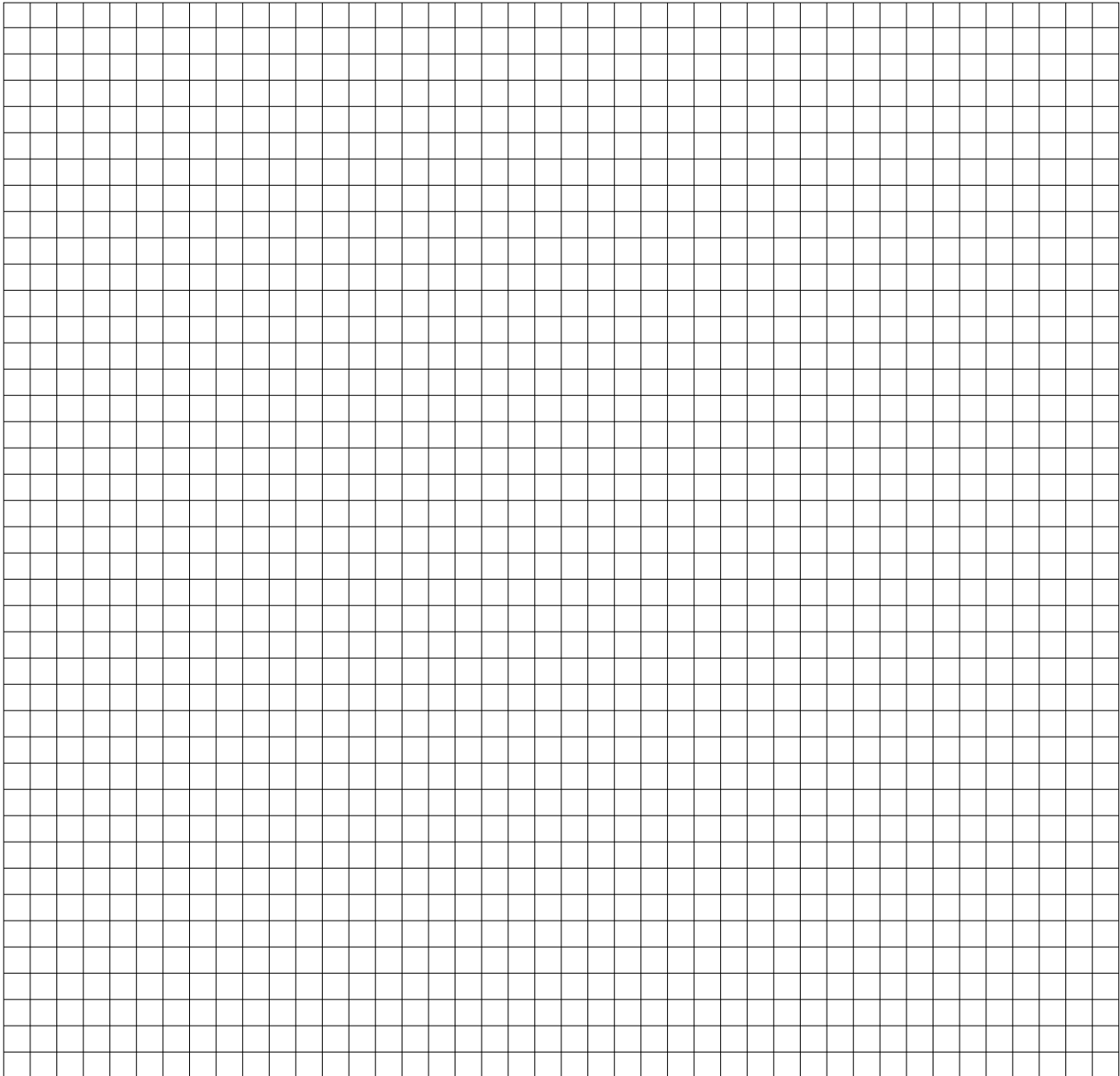

All dimensions in millimeters, unless otherwise specified



# SVTM E Series

## ATEX Brushless Motors







# SVTM E Series

## ATEX Brushless Motors



EXPLOSION PROOF



LOW VOLTAGE



STURDY

Our SVTM E Series Brushless Motors are characterised by an IC 400 type construction, thereby featuring a totally enclosed motor that does not require any type of additional ventilation. To ensure higher service life, most of the insulating materials are rated in the 200-degree class. In addition, the stator pack design with winding in the groove and using Neodymium magnets ensures high performance with small dimensions generating, as a result, a sinusoidal electromotive force. For enhanced application safety, a temperature sensor is mounted for each winding so as to prevent damage from overheating, thereby increasing motor service life.

Motors are tested in accordance with EN 60034-18-41 relating to partial discharge between windings. To increase the application range, the insulating materials used are UL certified. This motor complies with: ATEX Directive 94/9/EG, EN60079-0, EN60079-1.

In addition, the SVTM E series is certified as: ATEX II 2G Ex d IIB T4 Gb, GROUP II, CATEGORY 2G, TEMPERATURE CLASS T4 (135°C), EXPLOSION GROUP IIB, FLAMEPROOF ENCLOSURE PROTECTION D

### Benefits

ATEX II 2G Ex d IIB T4 Gb	Cable gland
High efficiency	
Low voltage	
Many feedback available	

F 02058 - 78 28 00 - 49  
 info@wagnergmbh.de  
 www.wagnergmbh.de

Robert-Bosch-Straße 35  
 42489 Wülfrath  
 T 02058 - 78 28 00 - 0



## Product code

1	2	3	4	5	6	7
SVTM	E	BB	- CCC -	DD -	EE -	F - GGG

- 1 Series: E
- 2 Frame: 01 [88]
- 3 Stall torque
- 4 BEMF
- 5 Feedback: resolver [R]; incremental encoder [E]; absolute encoder [A]
- 6 Brake: no [0]
- 7 Customisations

## Certifications

CE	ATEX II 2G Ex d IIB T4 Gb
RoHS 2011/65/EU	Group II
	Category 2G
	Temperature class T4 (135°C)
	Explosion group IIB
	Fameproof enclosure protection D

## Features

Sealing	IP54
Winding	3 phase sinusoidal
Operating temperature	-20° +40° C
Tested	EN 60034-18-41
Insulation class	F, 155° C
Thermal protection	PTC
Construction	IC 400
Connection	cable gland
Magnets	Neodymium
Insulators	UL
Construction technology:	high density fractional-slot concentrated-windings
Standard feedback	resolver
Directives	ATEX Directive 94/9/EG, EN60079-0, EN60079-1

### EN 60034-18-41

Partial discharge free electrical insulation systems (type 1) used in rotating electrical machines fed from voltage converters - qualification and quality control test.

# SVTM E

Values	Unit	SVTM E			
		01-01.4-12-x-0-000	01-01.6-32-x-0-000	01-02.6-20-x-0-000	01-02.6-56-x-0-000
Frame	□ [mm]	88	88	88	88
Length	L [Nm]	185	185	210	210
Continous stall torque	To [Nm]	1,4	1,6	2,6	2,6
BEMF constant (1)(2)	Ke [Vrms/krpm]	12,5	32,7	20,5	56,5
Resistance (1)(2)	R [Ohm]	0,85	5,5	0,85	5,8
Inductance (1)	L [mH]	2,05	14,1	2,25	17,2
Rotor inertia	J [kgcm <sup>2</sup> ]	1,06	1,06	1,7	1,7
Insulation class		F, 155°C	F, 155°C	F, 155°C	F, 155°C
Ambient temperature (3)	Ta [°C]	-20°C +40°C	-20°C +40°C	-20°C +40°C	-20°C +40°C
Protection degree		IP54	IP54	IP54	IP54
Max. axial load	Fa [N]	130	130	130	130
Max. radial load	Fr [N]	250	250	250	250
Mass	W [kg]	4,2	4,2	5,2	5,2
Thermal protection		PTC	PTC	PTC	PTC

Values	Unit	SVTM E		
		01-03.4-30-x-0-000	01-03.6-63-x-0-000	01-04.2-76-x-0-000
Frame	□ [mm]	88	88	88
Length	L [Nm]	235	235	250
Continous stall torque	To [Nm]	3,4	3,6	4,2
BEMF constant (1)(2)	Ke [Vrms/krpm]	30,5	63	76,4
Resistance (1)(2)	R [Ohm]	1,15	4	4,65
Inductance (1)	L [mH]	3,2	13,35	15,5
Rotor inertia	J [kgcm <sup>2</sup> ]	2,32	2,32	2,7
Insulation class		F, 155°C	F, 155°C	F, 155°C
Ambient temperature (3)	Ta [°C]	-20°C +40°C	-20°C +40°C	-20°C +40°C
Protection degree		IP54	IP54	IP54
Max. axial load	Fa [N]	130	130	130
Max. radial load	Fr [N]	250	250	250
Mass	W [kg]	6,2	6,2	6,8
Thermal protection		PTC	PTC	PTC

(1) Line-line

(2) At 20° C

(3) With no condensation

Note: Rated values are calculated at 20°C ambient temperature with an heat sink size of 300x300x20 mm

## Feedback

Resolver (Standard)

Incremental encoder with hall (on request)

Absolute feedback (on request)

Other on request

## Customisation

Shaft with key

Specific resolver phasing

Other voltage winding



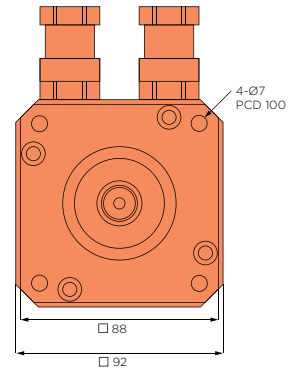
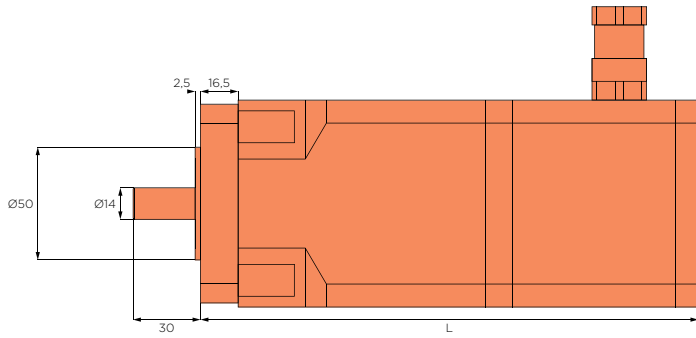
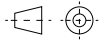

For torque curves see next page.

SVTM E

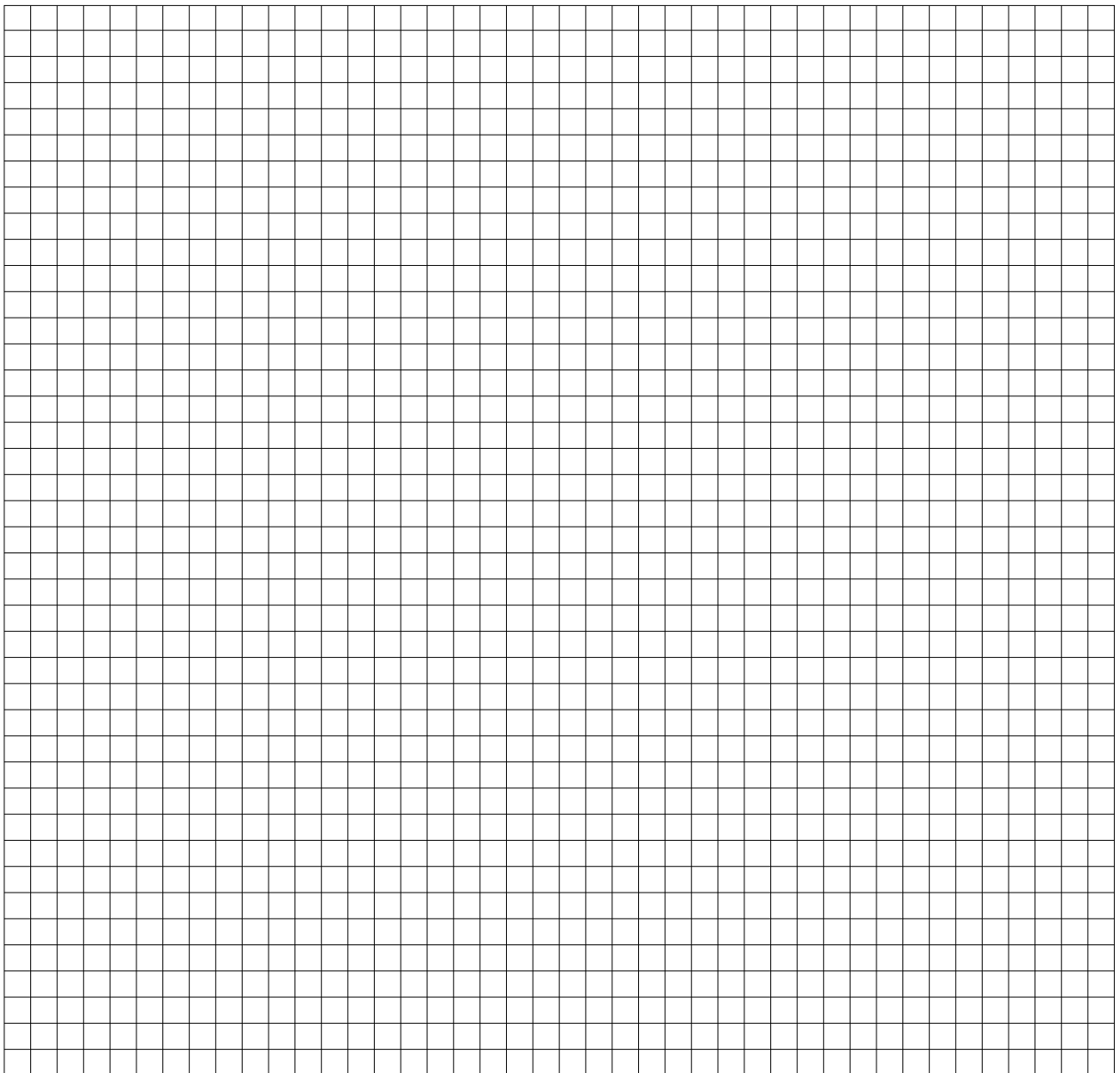

All dimensions in millimeters, unless otherwise specified



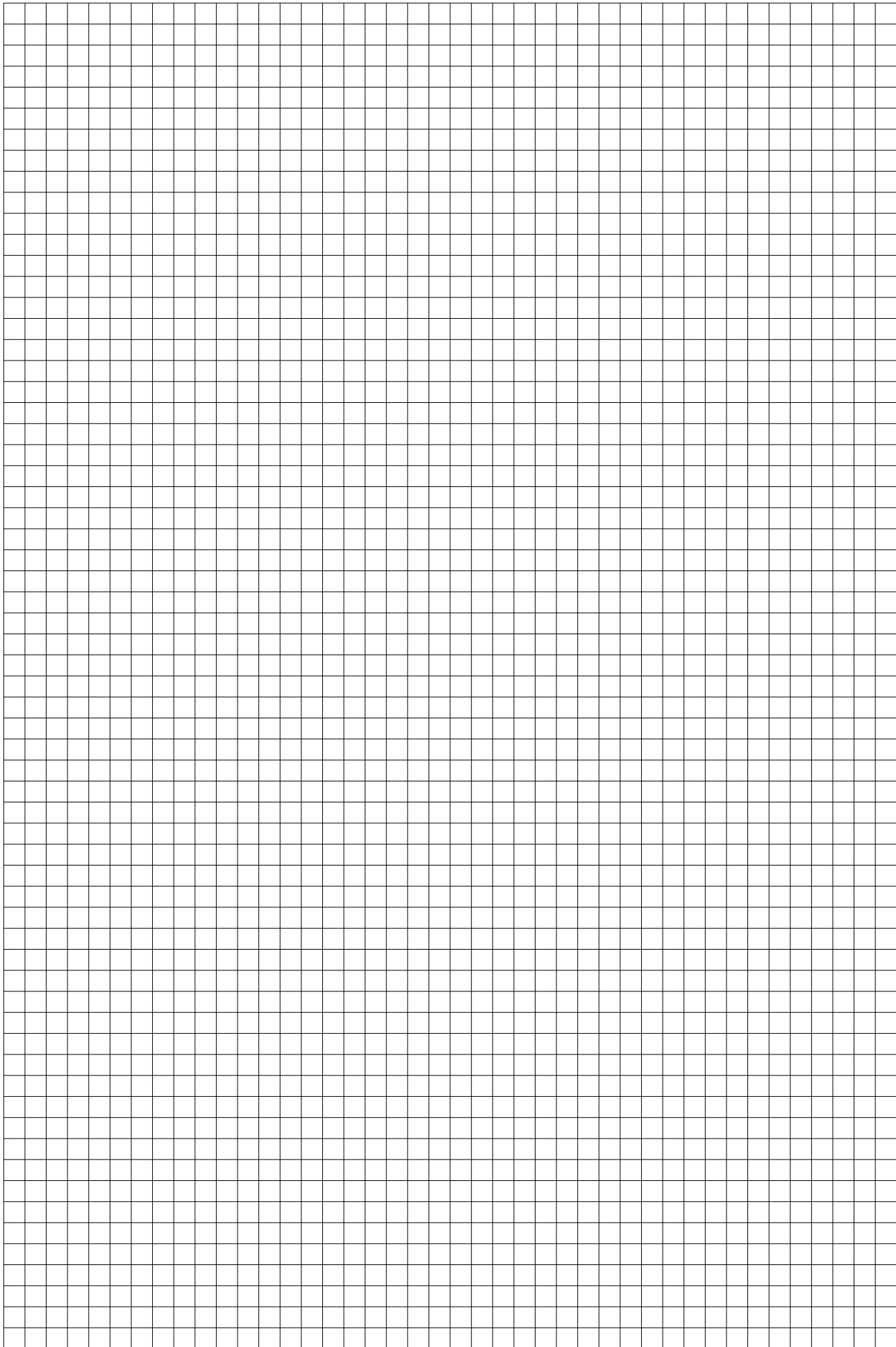

All dimensions in millimeters, unless otherwise specified



# Custom Motors

## Case histories



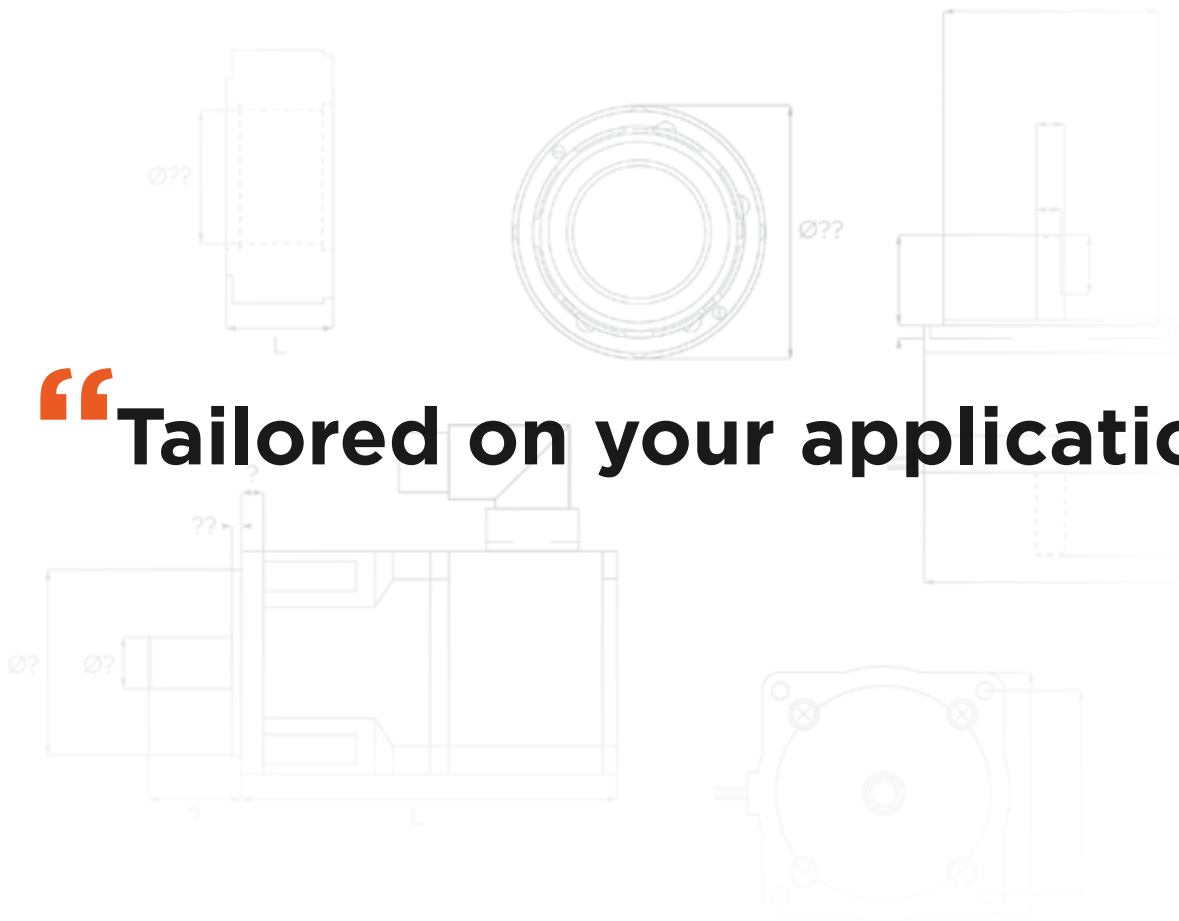

“Tailored on your application”

F 02058 - 78 28 00 - 49  
info@wagnergmbh.de  
www.wagnergmbh.de

Robert-Bosch-Straße 35  
42489 Wülfrath  
T 02058 - 78 28 00 - 0

**WAGNER GMBH**  
Elektrotechnische Systemlösungen



## Hand in hand engineering

Thanks to our multi-year application expertise and daily contact with motor designers, we are able to develop systems to be integrated into customers' machines. This is possible thanks to the fact that the customer communicates directly with the designers so that we can develop the best possible technical solution together.





## What can we customise?

- Shaft with key
- Wire drawing shaft
- Wire drawing flange
- Specific connectors
- Specific resolver phasing
- Thermal protection type on request
- Low voltage winding
- Feedback
- Other voltage winding
- Brake
- Frameless solutions

F 02058 - 78 28 00 - 49  
info@wagnergmbh.de  
www.wagnergmbh.de

Robert-Bosch-Straße 35  
42489 Wülfrath  
T 02058 - 78 28 00 - 0

**WAGNER GMBH**  
Elektrotechnische Systemlösungen



## SVTM 154 BR

### Brushless Pancake Motor

Motor developed for an application in the safety field to directly drive an optical viewing system. It meets shock, vibration and temperature criteria as per MIL-STD-810F standard.



Low voltage

Compact dimension

MIL-STD-810F

Outside diameter: 154 mm

Inside diameter: 101 mm

Torque: 30 Nm

Nominal voltage: 31.2 VDC

## SVTM 120 BR

### Brushless Frameless Motor

Motor developed for an application in the naval field to control the driving system and especially designed to be integrated into the customer's mechanical systems, with the lowest possible cogging in addition to zero electromagnetic emissions, so as to eliminate the risk of board instrumentation interference



Low cogging

Custom dimension

Hand in hand Engineering

Outside diameter: 120 mm

Inside diameter: 28 mm

Torque: 2.2 Nm

Nominal voltage: 24 VDC

F 02058 - 78 28 00 - 49  
info@wagnergmbh.de  
www.wagnergmbh.de

Robert-Bosch-Straße 35  
42489 Wülfrath  
T 02058 - 78 28 00 - 0

**WAGNER GMBH**  
Elektrotechnische Systemlösungen



## SVTM 90 BR

### Low Voltage Spindle Motor

Low voltage motor with a high number of revolutions, developed for a manual cutter application where, for operator safety issues, a 48Vdc supply voltage is recommended.



- High speed
- Low voltage
- Outside diameter: 90 mm
- Inside diameter: 15 mm
- Torque: 0.26 Nm
- Nominal voltage: 48 VDC
- Speed: 30.000 rpm

## SVTM 38 BR

### Low Voltage External Rotor Motor

External rotor motor with a small diameter, developed to be integrated into the cooling system of civil and military aircraft on-board electronics. Its specific reverse geometry design (external rotor) makes it possible to provide high torque and speed with respect to dimensions. The Brushless technology eliminates all wear problems.



- High speed
- Outer diameter
- Avionic application
- Outside diameter: 38 mm
- Inside diameter: 12 mm
- Torque: 0.11 Nm
- Nominal voltage: 28 VDC
- Speed: 15.000 rpm



## SVTM 80 B42

### High Temperature Motor

Motor for oven and autoclave applications with 200°C temperatures and environmental pressures of up to 10 bars. The motor is equipped with resolvers and can be supplied with an interface for the installation of a reducer.



Operating temperature: 200° C

Gearbox option

Resolver

Frame: 80 mm

Torque: 2 Nm

Nominal voltage: 60 VDC

Speed: 3.000 rpm

## SVTM 80 B

### IP67 / IP68 Motor

Motor for the directional movement of the flaps of an exploration submarine for scientific purposes. This motor is equipped with hall sensors to control speed.



High pressure

IP68 (200 meters)

Low voltage

Frame: 88 mm

Torque: 1.4 Nm

Nominal voltage: 48 VDC

Speed: 1.300 rpm

F 02058 - 78 28 00 - 49  
info@wagnergmbh.de  
www.wagnergmbh.de

Robert-Bosch-Straße 35  
42489 Wülfrath  
T 02058 - 78 28 00 - 0

**WAGNER GMBH**  
Elektrotechnische Systemlösungen



## SVTM 115 B31 IP68 Low Voltage Motor

Completely sealed motor with IP68 protection, developed for a maritime application in contact with salt water and vapour. The engine is equipped with negative brake and resolver.



- Low voltage
- IP68
- Frame: 115 mm
- Torque: 4.1 Nm
- Nominal voltage: 24 VDC
- Speed: 2.200 rpm

## SVTM 115 B IP69K Motor

Motor for the propulsion of a remotely operated underwater vehicle (ROUV). This motors needed to operate under salt water down to 20 meters.



- IP69K
- Material: stainless steel AISI 316
- Frame:  $\varnothing$  115 mm
- Torque: 7 Nm
- Nominal voltage: 48 VDC
- Speed: 1.300 rpm
- Shaft axial load: 500 N

## HEADQUARTERS - ITALY



**Servotecnica S.p.A.**  
Via E. Majorana, 4  
20834 Nova Milanese (MB)  
Italy  
+39 03624921 | [info@servotecnica.com](mailto:info@servotecnica.com)

## GERMANY, AUSTRIA, SWITZERLAND



**Servotecnica G.m.b.H.**  
Kelsterbacher Strasse, 20  
65479 Raunheim - Deutschland  
[info@servotecnica.de](mailto:info@servotecnica.de) | [www.servotecnica.de](http://www.servotecnica.de)

## FRANCE & BELGIUM



**Product Engineering Services S.A.**  
Zoning de La Rivière, 65  
B-7330 Saint-Ghislain - Belgique/België  
+32 (0) 65 764040 | [sales@pes-sa.com](mailto:sales@pes-sa.com) | [www.pes-sa.com](http://www.pes-sa.com)

## SPAIN



**JKE Robotics S.L.**  
Abanico de Plentzia, 176  
E-48620 Plentzia (Bizkaia) - España  
+34 946775730 | [info@jkerobotics.com](mailto:info@jkerobotics.com) | [www.jkerobotics.com](http://www.jkerobotics.com)

## UNITED KINGDOM



**Heason Technology Ltd.**  
Spring Copse Business Park  
Slinfold West Sussex - UK  
+44 (0) 1403 792300 | [info@heason.com](mailto:info@heason.com) | [www.heason.com](http://www.heason.com)

## IRELAND



**Callan Scientific Ltd.**  
Bay K, 12A/12B Shannon Industrial Estate, 4  
Co. Clare (Shannon) - Ireland  
+34 946775730 | [info@callanscientific.ie](mailto:info@callanscientific.ie) | [www.callanscientific.ie](http://www.callanscientific.ie)

F 02058 - 78 28 00 - 49  
[info@wagnergmbh.de](mailto:info@wagnergmbh.de)  
[www.wagnergmbh.de](http://www.wagnergmbh.de)

Robert-Bosch-Straße 35  
42489 Wülfrath  
T. 02058 - 78 28 00 - 0

**WAGNER GMBH**  
Elektrotechnische Systemlösungen



## ISRAEL



### Lewenstein Technologies Ltd.

Bareket St., 9  
Kiryat Matalon Petach-Tikva - 4951777 Israel  
+972 3-9780800 | info@l-tech.co.il | www.l-tech.co.il

## BULGARIA



### Master Ltd.

Lipnik Blvd., 123 - Business Park Rousse  
7013 Ruse - Bulgarija  
+35 982846539 | ruse@master-bg.com

## SLOVENIA



### Go TO d.o.o.

Ljubljanska cesta, 45  
1241 Kamnik - Slovenija  
+386 (0) 15190853 | info@goto.si | www.goto.si

Hello,  
how can I help you?



**WAGNER GMBH**  
Elektrotechnische Systemlösungen

Robert-Bosch-Straße 35  
42489 Wülfrath  
T 02058 - 78 28 00 - 0

F 02058 - 78 28 00 - 49  
info@wagnergmbh.de  
www.wagnergmbh.de